

MATH 304
Linear Algebra

Lecture 4:
Applications of systems of linear equations.

Applications of systems of linear equations

Problem 1. Find the point of intersection of the lines $x - y = -2$ and $2x + 3y = 6$ in \mathbb{R}^2 .

$$\begin{cases} x - y = -2 \\ 2x + 3y = 6 \end{cases}$$

Problem 2. Find the point of intersection of the planes $x - y = 2$, $2x - y - z = 3$, and $x + y + z = 6$ in \mathbb{R}^3 .

$$\begin{cases} x - y = 2 \\ 2x - y - z = 3 \\ x + y + z = 6 \end{cases}$$

Method of undetermined coefficients often involves solving systems of linear equations.

Problem 3. Find a quadratic polynomial $p(x)$ such that $p(1) = 4$, $p(2) = 3$, and $p(3) = 4$.

Suppose that $p(x) = ax^2 + bx + c$. Then
 $p(1) = a + b + c$, $p(2) = 4a + 2b + c$,
 $p(3) = 9a + 3b + c$.

$$\begin{cases} a + b + c = 4 \\ 4a + 2b + c = 3 \\ 9a + 3b + c = 4 \end{cases}$$

Method of undetermined coefficients often involves solving systems of linear equations.

Problem 3. Find a quadratic polynomial $p(x)$ such that $p(1) = 4$, $p(2) = 3$, and $p(3) = 4$.

Alternative choice of coefficients: $p(x) = \tilde{a} + \tilde{b}x + \tilde{c}x^2$.

Then $p(1) = \tilde{a} + \tilde{b} + \tilde{c}$, $p(2) = \tilde{a} + 2\tilde{b} + 4\tilde{c}$,
 $p(3) = \tilde{a} + 3\tilde{b} + 9\tilde{c}$.

$$\begin{cases} \tilde{a} + \tilde{b} + \tilde{c} = 4 \\ \tilde{a} + 2\tilde{b} + 4\tilde{c} = 3 \\ \tilde{a} + 3\tilde{b} + 9\tilde{c} = 4 \end{cases}$$

Problem 4. Evaluate $\int_0^1 \frac{x(x-3)}{(x-1)^2(x+2)} dx$.

To evaluate the integral, we need to decompose the rational function $R(x) = \frac{x(x-3)}{(x-1)^2(x+2)}$ into the sum of simple fractions:

$$\begin{aligned} R(x) &= \frac{a}{x-1} + \frac{b}{(x-1)^2} + \frac{c}{x+2} \\ &= \frac{a(x-1)(x+2) + b(x+2) + c(x-1)^2}{(x-1)^2(x+2)} \\ &= \frac{(a+c)x^2 + (a+b-2c)x + (-2a+2b+c)}{(x-1)^2(x+2)}. \end{aligned}$$

$$\begin{cases} a + c = 1 \\ a + b - 2c = -3 \\ -2a + 2b + c = 0 \end{cases}$$

Traffic flow

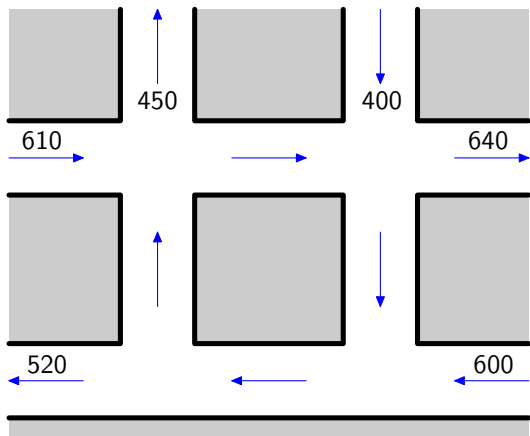

Problem. Determine the amount of traffic between each of the four intersections.

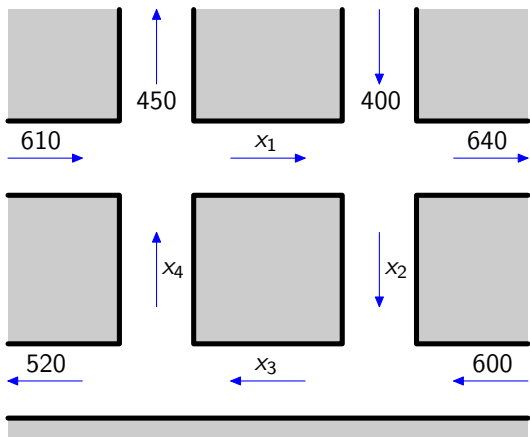

$$x_1 = ?, \quad x_2 = ?, \quad x_3 = ?, \quad x_4 = ?$$

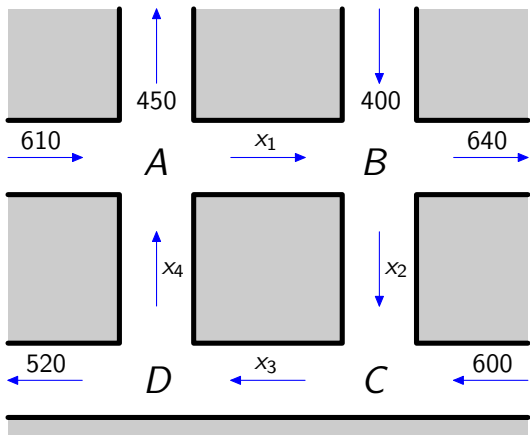

At each intersection, the incoming traffic has to match the outgoing traffic.

$$\text{Intersection } A: \quad x_4 + 610 = x_1 + 450$$

$$\text{Intersection } B: \quad x_1 + 400 = x_2 + 640$$

$$\text{Intersection } C: \quad x_2 + 600 = x_3$$

$$\text{Intersection } D: \quad x_3 = x_4 + 520$$

$$\begin{cases} x_4 + 610 = x_1 + 450 \\ x_1 + 400 = x_2 + 640 \\ x_2 + 600 = x_3 \\ x_3 = x_4 + 520 \end{cases}$$

$$\iff \begin{cases} -x_1 + x_4 = -160 \\ x_1 - x_2 = 240 \\ x_2 - x_3 = -600 \\ x_3 - x_4 = 520 \end{cases}$$

Electrical network

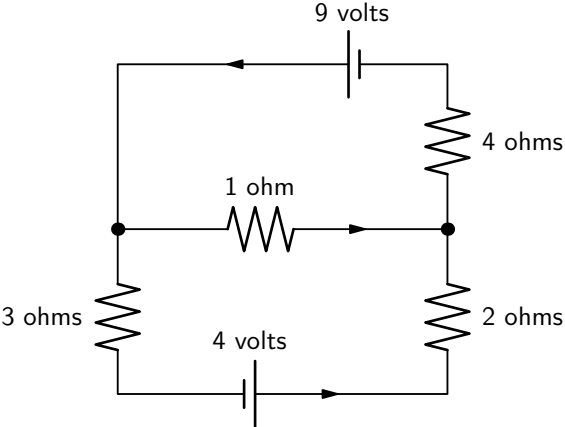

Problem. Determine the amount of current in each branch of the network.

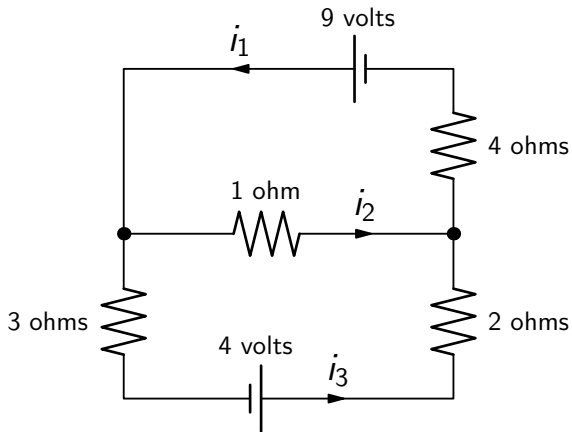

$$i_1 = ?, \quad i_2 = ?, \quad i_3 = ?$$

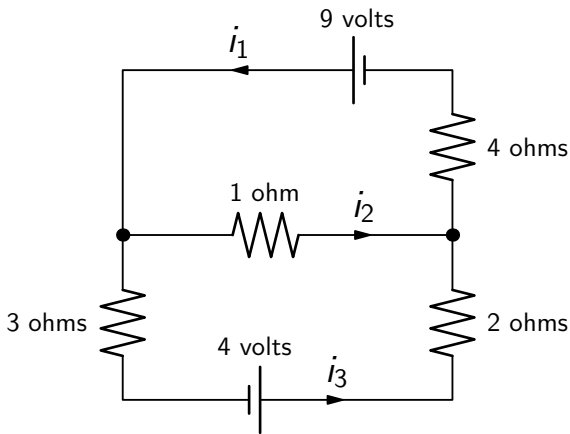

Kirchhof's law #1 (junction rule): at every node the sum of the incoming currents equals the sum of the outgoing currents.

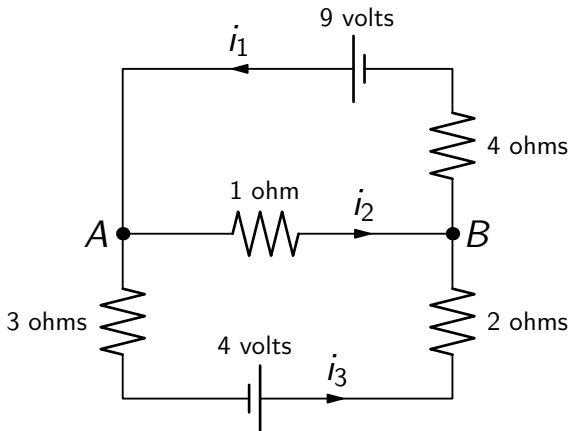

Node A: $i_1 = i_2 + i_3$

Node B: $i_2 + i_3 = i_1$

Electrical network

Kirchhof's law #2 (loop rule): around every loop the algebraic sum of all voltages is zero.

Ohm's law: for every resistor the voltage drop E , the current i , and the resistance R satisfy $E = iR$.

$$\text{Top loop:} \quad 9 - i_2 - 4i_1 = 0$$

$$\text{Bottom loop:} \quad 4 - 2i_3 + i_2 - 3i_3 = 0$$

$$\text{Big loop:} \quad 4 - 2i_3 - 4i_1 + 9 - 3i_3 = 0$$

Remark. The 3rd equation is the sum of the first two equations.

$$\begin{cases} i_1 = i_2 + i_3 \\ 9 - i_2 - 4i_1 = 0 \\ 4 - 2i_3 + i_2 - 3i_3 = 0 \end{cases}$$

$$\iff \begin{cases} i_1 - i_2 - i_3 = 0 \\ 4i_1 + i_2 = 9 \\ -i_2 + 5i_3 = 4 \end{cases}$$

Stress analysis of a truss

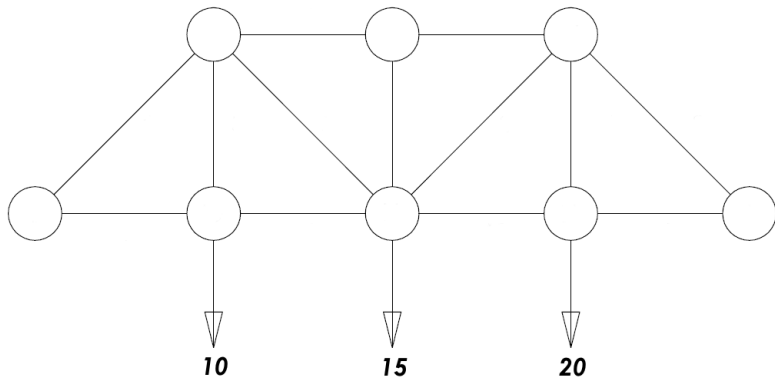

Problem. Assume that the leftmost and rightmost joints are fixed. Find the forces acting on each member of the truss.



Truss bridge

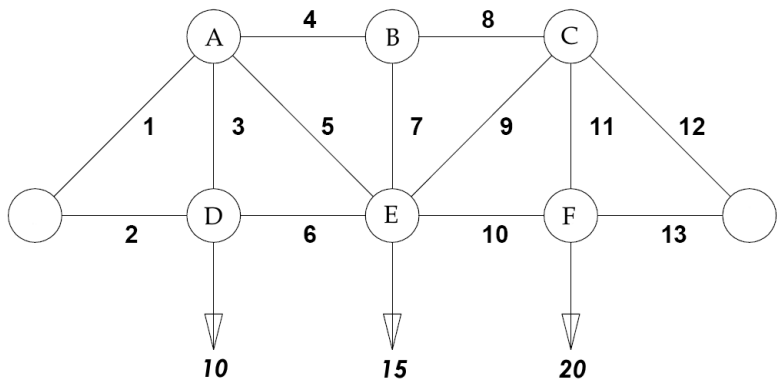

Let $|f_k|$ be the magnitude of the force in the k th member. $f_k > 0$ if the member is under tension. $f_k < 0$ if the member is under compression.

Static equilibrium at the joint A:

horizontal projection: $-\frac{1}{\sqrt{2}}f_1 + f_4 + \frac{1}{\sqrt{2}}f_5 = 0$

vertical projection: $-\frac{1}{\sqrt{2}}f_1 - f_3 - \frac{1}{\sqrt{2}}f_5 = 0$

Static equilibrium at the joint B:

horizontal projection: $-f_4 + f_8 = 0$

vertical projection: $-f_7 = 0$

Static equilibrium at the joint C:

horizontal projection: $-f_8 - \frac{1}{\sqrt{2}}f_9 + \frac{1}{\sqrt{2}}f_{12} = 0$

vertical projection: $-\frac{1}{\sqrt{2}}f_9 - f_{11} - \frac{1}{\sqrt{2}}f_{12} = 0$

Static equilibrium at the joint D:

horizontal projection: $-f_2 + f_6 = 0$

vertical projection: $f_3 - 10 = 0$

Static equilibrium at the joint E:

horizontal projection: $-\frac{1}{\sqrt{2}}f_5 - f_6 + \frac{1}{\sqrt{2}}f_9 + f_{10} = 0$

vertical projection: $\frac{1}{\sqrt{2}}f_5 + f_7 + \frac{1}{\sqrt{2}}f_9 - 15 = 0$

Static equilibrium at the joint F:

horizontal projection: $-f_{10} + f_{13} = 0$

vertical projection: $f_{11} - 20 = 0$

$$\left\{ \begin{array}{l}
 -\frac{1}{\sqrt{2}}f_1 + f_4 + \frac{1}{\sqrt{2}}f_5 = 0 \\
 -\frac{1}{\sqrt{2}}f_1 - f_3 - \frac{1}{\sqrt{2}}f_5 = 0 \\
 -f_4 + f_8 = 0 \\
 -f_7 = 0 \\
 -f_8 - \frac{1}{\sqrt{2}}f_9 + \frac{1}{\sqrt{2}}f_{12} = 0 \\
 -\frac{1}{\sqrt{2}}f_9 - f_{11} - \frac{1}{\sqrt{2}}f_{12} = 0 \\
 -f_2 + f_6 = 0 \\
 f_3 = 10 \\
 -\frac{1}{\sqrt{2}}f_5 - f_6 + \frac{1}{\sqrt{2}}f_9 + f_{10} = 0 \\
 \frac{1}{\sqrt{2}}f_5 + f_7 + \frac{1}{\sqrt{2}}f_9 = 15 \\
 -f_{10} + f_{13} = 0 \\
 f_{11} = 20
 \end{array} \right.$$