

MATH 311

Topics in Applied Mathematics

Lecture 3:

**Some applications of
systems of linear equations.**

Matrix algebra.

System with a parameter

$$\begin{cases} y + 3z = 0 \\ x + y - 2z = 0 \\ x + 2y + az = 0 \end{cases} \quad (a \in \mathbb{R})$$

The system is **homogeneous** (all right-hand sides are zeros). Therefore it is consistent ($x = y = z = 0$ is a solution).

Augmented matrix:
$$\left(\begin{array}{ccc|c} 0 & 1 & 3 & 0 \\ 1 & 1 & -2 & 0 \\ 1 & 2 & a & 0 \end{array} \right)$$

Since the 1st row cannot serve as a pivotal one, we interchange it with the 2nd row:

$$\left(\begin{array}{ccc|c} 0 & 1 & 3 & 0 \\ 1 & 1 & -2 & 0 \\ 1 & 2 & a & 0 \end{array} \right) \rightarrow \left(\begin{array}{ccc|c} 1 & 1 & -2 & 0 \\ 0 & 1 & 3 & 0 \\ 1 & 2 & a & 0 \end{array} \right)$$

Now we can start the elimination.

First subtract the 1st row from the 3rd row:

$$\left(\begin{array}{ccc|c} 1 & 1 & -2 & 0 \\ 0 & 1 & 3 & 0 \\ 1 & 2 & a & 0 \end{array} \right) \rightarrow \left(\begin{array}{ccc|c} 1 & 1 & -2 & 0 \\ 0 & 1 & 3 & 0 \\ 0 & 1 & a+2 & 0 \end{array} \right)$$

The 2nd row is our new pivotal row.

Subtract the 2nd row from the 3rd row:

$$\left(\begin{array}{ccc|c} 1 & 1 & -2 & 0 \\ 0 & 1 & 3 & 0 \\ 0 & 1 & a+2 & 0 \end{array} \right) \rightarrow \left(\begin{array}{ccc|c} 1 & 1 & -2 & 0 \\ 0 & 1 & 3 & 0 \\ 0 & 0 & a-1 & 0 \end{array} \right)$$

At this point row reduction splits into two cases.

Case 1: $a \neq 1$. In this case, multiply the 3rd row by $(a - 1)^{-1}$:

$$\left(\begin{array}{ccc|c} 1 & 1 & -2 & 0 \\ 0 & 1 & 3 & 0 \\ 0 & 0 & a-1 & 0 \end{array} \right) \rightarrow \left(\begin{array}{ccc|c} \boxed{1} & 1 & -2 & 0 \\ 0 & \boxed{1} & 3 & 0 \\ 0 & 0 & \boxed{1} & 0 \end{array} \right)$$

The matrix is converted into row echelon form.

We proceed towards reduced row echelon form.

Subtract 3 times the 3rd row from the 2nd row:

$$\left(\begin{array}{ccc|c} 1 & 1 & -2 & 0 \\ 0 & 1 & 3 & 0 \\ 0 & 0 & 1 & 0 \end{array} \right) \rightarrow \left(\begin{array}{ccc|c} 1 & 1 & -2 & 0 \\ 0 & 1 & 0 & 0 \\ 0 & 0 & 1 & 0 \end{array} \right)$$

Add 2 times the 3rd row to the 1st row:

$$\left(\begin{array}{ccc|c} 1 & 1 & -2 & 0 \\ 0 & 1 & 0 & 0 \\ 0 & 0 & 1 & 0 \end{array} \right) \rightarrow \left(\begin{array}{ccc|c} 1 & 1 & 0 & 0 \\ 0 & 1 & 0 & 0 \\ 0 & 0 & 1 & 0 \end{array} \right)$$

Finally, subtract the 2nd row from the 1st row:

$$\left(\begin{array}{ccc|c} 1 & 1 & 0 & 0 \\ 0 & 1 & 0 & 0 \\ 0 & 0 & 1 & 0 \end{array} \right) \rightarrow \left(\begin{array}{ccc|c} \boxed{1} & 0 & 0 & 0 \\ 0 & \boxed{1} & 0 & 0 \\ 0 & 0 & \boxed{1} & 0 \end{array} \right)$$

Thus $x = y = z = 0$ is the only solution.

Case 2: $a = 1$. In this case, the matrix is already in row echelon form:

$$\left(\begin{array}{ccc|c} \boxed{1} & 1 & -2 & 0 \\ 0 & \boxed{1} & 3 & 0 \\ 0 & 0 & 0 & 0 \end{array} \right)$$

To get reduced row echelon form, subtract the 2nd row from the 1st row:

$$\left(\begin{array}{ccc|c} 1 & 1 & -2 & 0 \\ 0 & 1 & 3 & 0 \\ 0 & 0 & 0 & 0 \end{array} \right) \rightarrow \left(\begin{array}{ccc|c} \boxed{1} & 0 & -5 & 0 \\ 0 & \boxed{1} & 3 & 0 \\ 0 & 0 & 0 & 0 \end{array} \right)$$

z is a free variable.

$$\begin{cases} x - 5z = 0 \\ y + 3z = 0 \end{cases} \iff \begin{cases} x = 5z \\ y = -3z \end{cases}$$

General solution: $(x, y, z) = (5t, -3t, t)$, $t \in \mathbb{R}$.

System of linear equations:

$$\begin{cases} y + 3z = 0 \\ x + y - 2z = 0 \\ x + 2y + az = 0 \end{cases}$$

Solution: If $a \neq 1$ then $(x, y, z) = (0, 0, 0)$;
if $a = 1$ then $(x, y, z) = (5t, -3t, t)$, $t \in \mathbb{R}$.

Applications of systems of linear equations

Problem 1. Find the point of intersection of the lines $x - y = -2$ and $2x + 3y = 6$ in \mathbb{R}^2 .

$$\begin{cases} x - y = -2 \\ 2x + 3y = 6 \end{cases}$$

Problem 2. Find the point of intersection of the planes $x - y = 2$, $2x - y - z = 3$, and $x + y + z = 6$ in \mathbb{R}^3 .

$$\begin{cases} x - y = 2 \\ 2x - y - z = 3 \\ x + y + z = 6 \end{cases}$$

Method of undetermined coefficients often involves solving systems of linear equations.

Problem 3. Find a quadratic polynomial $p(x)$ such that $p(1) = 4$, $p(2) = 3$, and $p(3) = 4$.

Suppose that $p(x) = ax^2 + bx + c$. Then
 $p(1) = a + b + c$, $p(2) = 4a + 2b + c$,
 $p(3) = 9a + 3b + c$.

$$\begin{cases} a + b + c = 4 \\ 4a + 2b + c = 3 \\ 9a + 3b + c = 4 \end{cases}$$

Problem 4. Evaluate $\int_0^1 \frac{x(x-3)}{(x-1)^2(x+2)} dx$.

To evaluate the integral, we need to decompose the rational function $R(x) = \frac{x(x-3)}{(x-1)^2(x+2)}$ into the sum of simple fractions:

$$\begin{aligned} R(x) &= \frac{a}{x-1} + \frac{b}{(x-1)^2} + \frac{c}{x+2} \\ &= \frac{a(x-1)(x+2) + b(x+2) + c(x-1)^2}{(x-1)^2(x+2)} \\ &= \frac{(a+c)x^2 + (a+b-2c)x + (-2a+2b+c)}{(x-1)^2(x+2)}. \end{aligned}$$

$$\begin{cases} a + c = 1 \\ a + b - 2c = -3 \\ -2a + 2b + c = 0 \end{cases}$$

Traffic flow

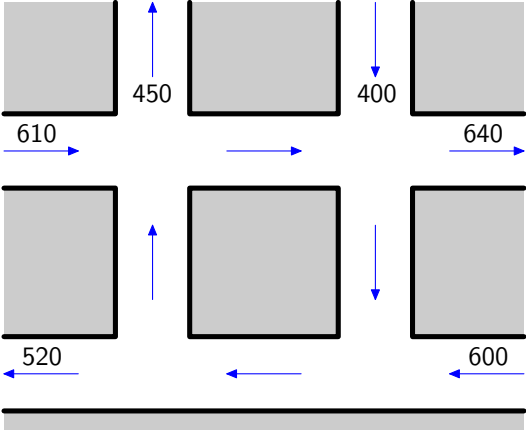

Problem. Determine the amount of traffic between each of the four intersections.

Traffic flow

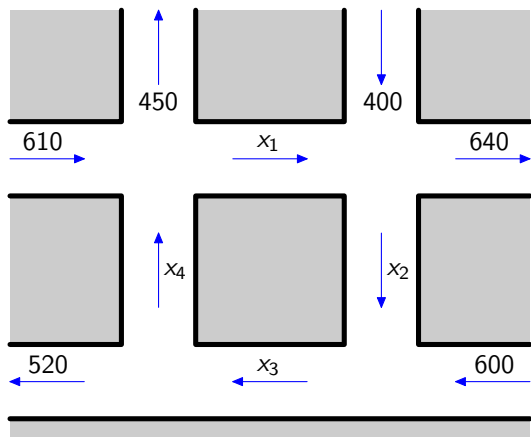

$$x_1 = ?, \quad x_2 = ?, \quad x_3 = ?, \quad x_4 = ?$$

Traffic flow

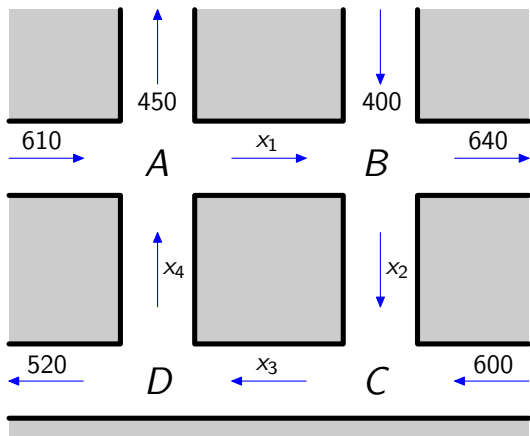

At each intersection, the incoming traffic has to match the outgoing traffic.

$$\text{Intersection } A: \quad x_4 + 610 = x_1 + 450$$

$$\text{Intersection } B: \quad x_1 + 400 = x_2 + 640$$

$$\text{Intersection } C: \quad x_2 + 600 = x_3$$

$$\text{Intersection } D: \quad x_3 = x_4 + 520$$

$$\begin{cases} x_4 + 610 = x_1 + 450 \\ x_1 + 400 = x_2 + 640 \\ x_2 + 600 = x_3 \\ x_3 = x_4 + 520 \end{cases}$$

$$\iff \begin{cases} -x_1 + x_4 = -160 \\ x_1 - x_2 = 240 \\ x_2 - x_3 = -600 \\ x_3 - x_4 = 520 \end{cases}$$

Electrical network

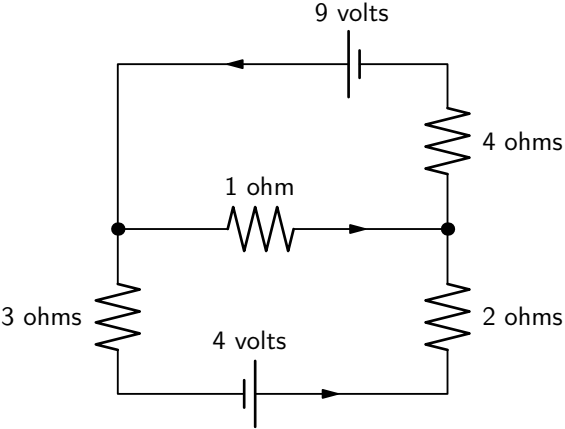

Problem. Determine the amount of current in each branch of the network.

Electrical network

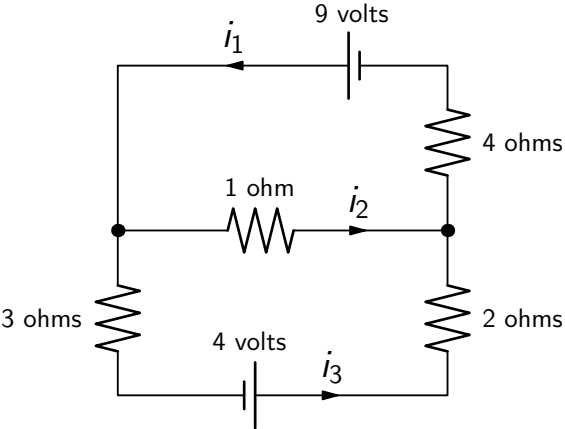

$$i_1 = ?, \quad i_2 = ?, \quad i_3 = ?$$

Electrical network

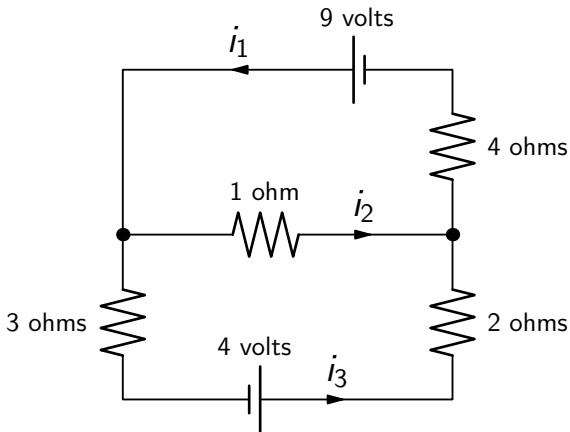

Kirchhoff's law #1 (junction rule): at every node the sum of the incoming currents equals the sum of the outgoing currents.

Electrical network

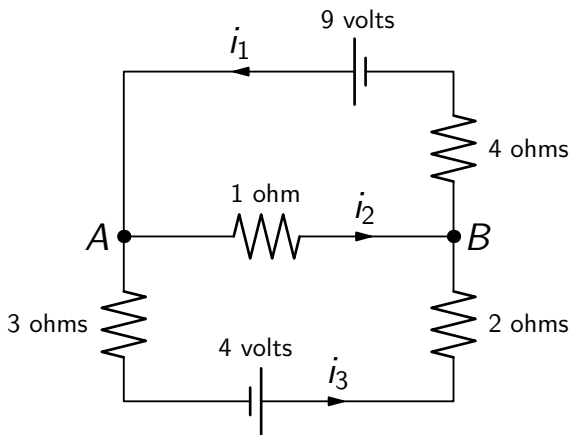

Node A: $i_1 = i_2 + i_3$

Node B: $i_2 + i_3 = i_1$

Electrical network

Kirchhof's law #2 (loop rule): around every loop the algebraic sum of all voltages is zero.

Ohm's law: for every resistor the voltage drop E , the current i , and the resistance R satisfy $E = iR$.

$$\text{Top loop:} \quad 9 - i_2 - 4i_1 = 0$$

$$\text{Bottom loop:} \quad 4 - 2i_3 + i_2 - 3i_3 = 0$$

$$\text{Big loop:} \quad 4 - 2i_3 - 4i_1 + 9 - 3i_3 = 0$$

Remark. The 3rd equation is the sum of the first two equations.

$$\begin{cases} i_1 = i_2 + i_3 \\ 9 - i_2 - 4i_1 = 0 \\ 4 - 2i_3 + i_2 - 3i_3 = 0 \end{cases}$$

$$\iff \begin{cases} i_1 - i_2 - i_3 = 0 \\ 4i_1 + i_2 = 9 \\ -i_2 + 5i_3 = 4 \end{cases}$$

Matrices

Definition. An **m-by-n matrix** is a rectangular array of numbers that has m rows and n columns:

$$\begin{pmatrix} a_{11} & a_{12} & \dots & a_{1n} \\ a_{21} & a_{22} & \dots & a_{2n} \\ \vdots & \vdots & \ddots & \vdots \\ a_{m1} & a_{m2} & \dots & a_{mn} \end{pmatrix}$$

Notation: $A = (a_{ij})_{1 \leq i \leq n, 1 \leq j \leq m}$ or simply $A = (a_{ij})$ if the dimensions are known.

An n -dimensional vector can be represented as a $1 \times n$ matrix (row vector) or as an $n \times 1$ matrix (column vector):

$$(x_1, x_2, \dots, x_n)$$

$$\begin{pmatrix} x_1 \\ x_2 \\ \vdots \\ x_n \end{pmatrix}$$

An $m \times n$ matrix $A = (a_{ij})$ can be regarded as a column of n -dimensional row vectors or as a row of m -dimensional column vectors:

$$A = \begin{pmatrix} \mathbf{v}_1 \\ \mathbf{v}_2 \\ \vdots \\ \mathbf{v}_m \end{pmatrix}, \quad \mathbf{v}_i = (a_{i1}, a_{i2}, \dots, a_{in})$$

$$A = (\mathbf{w}_1, \mathbf{w}_2, \dots, \mathbf{w}_n), \quad \mathbf{w}_j = \begin{pmatrix} a_{1j} \\ a_{2j} \\ \vdots \\ a_{mj} \end{pmatrix}$$

Vector algebra

Let $\mathbf{a} = (a_1, a_2, \dots, a_n)$ and $\mathbf{b} = (b_1, b_2, \dots, b_n)$ be n -dimensional vectors, and $r \in \mathbb{R}$ be a scalar.

Vector sum: $\mathbf{a} + \mathbf{b} = (a_1 + b_1, a_2 + b_2, \dots, a_n + b_n)$

Scalar multiple: $r\mathbf{a} = (ra_1, ra_2, \dots, ra_n)$

Zero vector: $\mathbf{0} = (0, 0, \dots, 0)$

Negative of a vector: $-\mathbf{b} = (-b_1, -b_2, \dots, -b_n)$

Vector difference:

$\mathbf{a} - \mathbf{b} = \mathbf{a} + (-\mathbf{b}) = (a_1 - b_1, a_2 - b_2, \dots, a_n - b_n)$

Given n -dimensional vectors $\mathbf{v}_1, \mathbf{v}_2, \dots, \mathbf{v}_k$ and scalars r_1, r_2, \dots, r_k , the expression

$$r_1\mathbf{v}_1 + r_2\mathbf{v}_2 + \dots + r_k\mathbf{v}_k$$

is called a **linear combination** of vectors $\mathbf{v}_1, \mathbf{v}_2, \dots, \mathbf{v}_k$.

Also, *vector addition* and *scalar multiplication* are called **linear operations**.

$$\begin{cases} a_{11}x_1 + a_{12}x_2 + \cdots + a_{1n}x_n = b_1 \\ a_{21}x_1 + a_{22}x_2 + \cdots + a_{2n}x_n = b_2 \\ \dots\dots\dots \\ a_{m1}x_1 + a_{m2}x_2 + \cdots + a_{mn}x_n = b_m \end{cases}$$

Vector representation of the system:

$$x_1 \begin{pmatrix} a_{11} \\ a_{21} \\ \vdots \\ a_{m1} \end{pmatrix} + x_2 \begin{pmatrix} a_{12} \\ a_{22} \\ \vdots \\ a_{m2} \end{pmatrix} + \cdots + x_n \begin{pmatrix} a_{1n} \\ a_{2n} \\ \vdots \\ a_{mn} \end{pmatrix} = \begin{pmatrix} b_1 \\ b_2 \\ \vdots \\ b_m \end{pmatrix}$$

Theorem The above system is consistent if and only if the vector of right-hand sides is a *linear combination* of columns of the coefficient matrix.

Matrix algebra

Definition. Let $A = (a_{ij})$ and $B = (b_{ij})$ be $m \times n$ matrices. The **sum** $A + B$ is defined to be the $m \times n$ matrix $C = (c_{ij})$ such that $c_{ij} = a_{ij} + b_{ij}$ for all indices i, j .

That is, two matrices with the same dimensions can be added by adding their corresponding entries.

$$\begin{pmatrix} a_{11} & a_{12} \\ a_{21} & a_{22} \\ a_{31} & a_{32} \end{pmatrix} + \begin{pmatrix} b_{11} & b_{12} \\ b_{21} & b_{22} \\ b_{31} & b_{32} \end{pmatrix} = \begin{pmatrix} a_{11} + b_{11} & a_{12} + b_{12} \\ a_{21} + b_{21} & a_{22} + b_{22} \\ a_{31} + b_{31} & a_{32} + b_{32} \end{pmatrix}$$

Definition. Given an $m \times n$ matrix $A = (a_{ij})$ and a number r , the **scalar multiple** rA is defined to be the $m \times n$ matrix $D = (d_{ij})$ such that $d_{ij} = ra_{ij}$ for all indices i, j .

That is, to multiply a matrix by a scalar r , one multiplies each entry of the matrix by r .

$$r \begin{pmatrix} a_{11} & a_{12} & a_{13} \\ a_{21} & a_{22} & a_{23} \\ a_{31} & a_{32} & a_{33} \end{pmatrix} = \begin{pmatrix} ra_{11} & ra_{12} & ra_{13} \\ ra_{21} & ra_{22} & ra_{23} \\ ra_{31} & ra_{32} & ra_{33} \end{pmatrix}$$

The $m \times n$ **zero matrix** (all entries are zeros) is denoted O_{mn} or simply O .

Negative of a matrix: $-A$ is defined as $(-1)A$.

Matrix **difference**: $A - B$ is defined as $A + (-B)$.

As far as the *linear operations* (addition and scalar multiplication) are concerned, the $m \times n$ matrices can be regarded as mn -dimensional vectors.

Examples

$$A = \begin{pmatrix} 3 & 2 & -1 \\ 1 & 1 & 1 \end{pmatrix}, \quad B = \begin{pmatrix} 2 & 0 & 1 \\ 0 & 1 & 1 \end{pmatrix},$$

$$C = \begin{pmatrix} 2 & 0 \\ 0 & 1 \end{pmatrix}, \quad D = \begin{pmatrix} 1 & 1 \\ 0 & 1 \end{pmatrix}.$$

$$A + B = \begin{pmatrix} 5 & 2 & 0 \\ 1 & 2 & 2 \end{pmatrix}, \quad A - B = \begin{pmatrix} 1 & 2 & -2 \\ 1 & 0 & 0 \end{pmatrix},$$

$$2C = \begin{pmatrix} 4 & 0 \\ 0 & 2 \end{pmatrix}, \quad 3D = \begin{pmatrix} 3 & 3 \\ 0 & 3 \end{pmatrix},$$

$$2C + 3D = \begin{pmatrix} 7 & 3 \\ 0 & 5 \end{pmatrix}, \quad A + D \text{ is not defined.}$$

Properties of linear operations

$$(A + B) + C = A + (B + C)$$

$$A + B = B + A$$

$$A + O = O + A = A$$

$$A + (-A) = (-A) + A = O$$

$$r(sA) = (rs)A$$

$$r(A + B) = rA + rB$$

$$(r + s)A = rA + sA$$

$$1A = A$$

$$0A = O$$

Dot product

Definition. The **dot product** of n -dimensional vectors $\mathbf{x} = (x_1, x_2, \dots, x_n)$ and $\mathbf{y} = (y_1, y_2, \dots, y_n)$ is a scalar

$$\mathbf{x} \cdot \mathbf{y} = x_1y_1 + x_2y_2 + \cdots + x_ny_n = \sum_{k=1}^n x_ky_k.$$

The dot product is also called the **scalar product**.

Matrix multiplication

The product of matrices A and B is defined if the number of columns in A matches the number of rows in B .

Definition. Let $A = (a_{ik})$ be an $m \times n$ matrix and $B = (b_{kj})$ be an $n \times p$ matrix. The **product** AB is defined to be the $m \times p$ matrix $C = (c_{ij})$ such that

$$c_{ij} = \sum_{k=1}^n a_{ik} b_{kj} \text{ for all indices } i, j.$$

That is, matrices are multiplied **row by column**:

$$\begin{pmatrix} * & * & * \\ \boxed{*} & \boxed{*} & \boxed{*} \end{pmatrix} \begin{pmatrix} * & * & \boxed{*} & * \\ * & * & * & * \\ * & * & * & * \end{pmatrix} = \begin{pmatrix} * & * & * & * \\ * & * & \boxed{*} & * \end{pmatrix}$$

$$A = \begin{pmatrix} a_{11} & a_{12} & \dots & a_{1n} \\ a_{21} & a_{22} & \dots & a_{2n} \\ \vdots & \vdots & \ddots & \vdots \\ a_{m1} & a_{m2} & \dots & a_{mn} \end{pmatrix} = \begin{pmatrix} \mathbf{v}_1 \\ \mathbf{v}_2 \\ \vdots \\ \mathbf{v}_m \end{pmatrix}$$

$$B = \left(\begin{array}{c|c|c|c} b_{11} & b_{12} & \dots & b_{1p} \\ b_{21} & b_{22} & \dots & b_{2p} \\ \vdots & \vdots & \ddots & \vdots \\ b_{n1} & b_{n2} & \dots & b_{np} \end{array} \right) = (\mathbf{w}_1, \mathbf{w}_2, \dots, \mathbf{w}_p)$$

$$\Rightarrow AB = \begin{pmatrix} \mathbf{v}_1 \cdot \mathbf{w}_1 & \mathbf{v}_1 \cdot \mathbf{w}_2 & \dots & \mathbf{v}_1 \cdot \mathbf{w}_p \\ \mathbf{v}_2 \cdot \mathbf{w}_1 & \mathbf{v}_2 \cdot \mathbf{w}_2 & \dots & \mathbf{v}_2 \cdot \mathbf{w}_p \\ \vdots & \vdots & \ddots & \vdots \\ \mathbf{v}_m \cdot \mathbf{w}_1 & \mathbf{v}_m \cdot \mathbf{w}_2 & \dots & \mathbf{v}_m \cdot \mathbf{w}_p \end{pmatrix}$$