

## Two-point spectral correlations for star graphs

G Berkolaiko and J P Keating

School of Mathematics, University of Bristol, University Walk, Bristol BS8 1TW, UK

and

BRIMS, Hewlett-Packard Laboratories, Filton Road, Stoke Gifford, Bristol BS12 6QZ, UK

Received 10 August 1999

**Abstract.** The eigenvalues of the Schrödinger operator on a graph  $G$  are related via an exact trace formula to periodic orbits on  $G$ . This connection is used to calculate two-point spectral statistics for a particular family of graphs, called star graphs, in the limit as the number of edges tends to infinity. Combinatorial techniques are used to evaluate both the diagonal (same orbit) and off-diagonal (different orbit) contributions to the sum over pairs of orbits involved. In this way, a general formula is derived for terms in the (short-time) expansion of the form factor  $K(\tau)$  in powers of  $\tau$ , and the first few are computed explicitly. The result demonstrates that  $K(\tau)$  is neither Poissonian nor random matrix, but an intermediate between the two. Off-diagonal pairs of orbits are shown to make a significant contribution to all but the first few coefficients.

### 1. Introduction

The Schrödinger operator on a graph provides a model for investigating quantum spectral statistics and their relation to periodic orbit theory. The trace formula, which links the eigenvalues to the classical periodic orbits of a graph, is an identity, and numerical studies have shown that the universal random-matrix features observed in the energy-level correlations of classically chaotic systems are present in the spectra of typical graphs [4–6].

The trace formula relates the two-point spectral correlation function  $R_2(x)$  to a sum over all pairs of periodic orbits. In the case of ‘generic’ graphs, standard semiclassical techniques [1–3], based on approximating this sum by only evaluating the diagonal (same orbit, modulo symmetry) contributions, can be used to explain some universal features of  $R_2(x)$  as the number of edges tends to infinity [4,5]. Specifically, they show that the first term in the expansion of the form factor  $K(\tau)$ —the Fourier transform of  $R_2(x)$ —in powers of  $\tau$  around  $\tau = 0$  coincides with the corresponding random-matrix results.

Alternatively, combinatorial methods have been used [6] to show that the two-point spectral correlations of small graphs coincide with those of correspondingly small random matrices.

In this paper we concentrate on a family of graphs, called *star graphs*, which have a particularly simple structure. A  $v$ -star graph consists of a vertex connected to  $v$  other vertices in a star shape, as the name suggests. The form factor was computed numerically for a number of star graphs and evaluated using a method equivalent to the diagonal approximation in [5]. The results suggest that when the number of edges is large, the two-point statistics are intermediate between those of random matrix theory and a Poisson distribution. We confirm this here by developing a general combinatorial method for calculating terms in the expansion of  $K(\tau)$  in powers of  $\tau$  about  $\tau = 0$ , in the limit as the number of edges tends to infinity, and under some restrictions on the individual lengths of the edges. The first few terms are obtained

explicitly. Crucially, this method enables us to evaluate both the diagonal and off-diagonal (different orbit) contributions. The off-diagonal contribution is nonzero for all but the first few coefficients.

Quantum graphs and their spectral statistics are described in more detail in section 2. We calculate the coefficients in the expansion of the form factor in section 3. Finally, in section 4, we discuss the diagonal approximation and compare it with the full expansion. Some combinatorial parts of the analysis are deferred until the appendix.

## 2. Quantum eigenvalues on graphs

Let  $G = (V, E)$  be a graph, where  $V$  is the set of vertices (nodes) and  $E \subset V \times V$  is the set of edges (bonds). It is assumed that if  $e = (i, j) \in E$  then  $\bar{e} = (j, i) \in E$ . Every edge  $e \in E$  has a length  $l^e$  ( $l^e = l^{\bar{e}}$ ) associated with it, and we shall assume that these lengths are rationally independent (incommensurate).

Define a Schrödinger equation on the edge  $e = (k, j)$ :

$$-\frac{d^2}{dx^2}\Psi_e(x) = \lambda^2\Psi_e(x) \quad (1)$$

where  $x \in [0, l^e]$  is the distance along  $e$ , with  $x = 0$  corresponding to the vertex  $k$  and  $x = l^e$  to the vertex  $j$ . We require the wavefunctions on different edges to be matched at the vertices

$$\Psi_{e_1}(0) = \Psi_{e_2}(0) \quad \text{if } e_1 = (k, j_1) \quad e_2 = (k, j_2) \quad (2)$$

and to satisfy the Neumann current conservation condition,

$$\sum_j \frac{d}{dx}\Psi_{kj} \Big|_{x=0} = 0. \quad (3)$$

Solving (1) and applying the boundary conditions we get the following equation for the eigenvalues  $\lambda$  [5]:

$$\det(I - \exp\{-i\lambda L\}S) = 0 \quad (4)$$

where  $L$  is the diagonal  $|E| \times |E|$  matrix with the lengths  $l^e$  as its diagonal elements, and the elements of the matrix  $S$  are given by

$$S_{(j,k),(k,j')} = -\delta_{j,j'} + 2/v_k \quad (5)$$

where  $v_k = \#\{j: (k, j) \in E\}$  is the valency of the vertex  $k$ , and  $\delta_{j,j'}$  is the Kronecker delta.  $S$  can be interpreted as the matrix of weights of the corresponding edge-to-edge transitions. The transition from the edge  $(j, k)$  to the edge  $(k, j)$  is called *backscattering*, while other transitions are referred to as *normal scattering*.

An exact trace formula for the eigenvalues  $\{\lambda_k\}$  was derived in [5]. If  $d(\lambda) = \sum \delta(\lambda - \lambda_n)$  is the spectral density, then

$$d(\lambda) = \frac{L}{2\pi} + \pi^{-1} \sum_{n, p \in \tilde{P}_n} \frac{l_p}{r_p} A_p \cos(\lambda l_p) \quad (6)$$

where  $p = (p_0, p_1, \dots, p_n)$ ,  $p_i \in E$ , labels a periodic orbit of period  $n$  ( $p_0 = p_n$ ),  $r_p$  is the repetition number of the orbit  $p$ ,  $L$  is the sum of lengths of all the edges,  $\tilde{P}_n$  is the set of all (up to a shift) periodic orbits of period  $n$ ,  $l_p = \sum_{i=1}^n l^{p_i}$  is the length of the periodic orbit  $p$ , and  $A_p = \prod_{i=1}^n S_{p_{i-1}, p_i}$  is the product of the matrix elements of  $S$  along the orbit.

In the present work we study one spectral function, the form factor (defined in section 3) for a special family of graphs, known as *star graphs*. These are graphs with  $v + 1$  vertices marked  $0$  to  $v$  and  $E = \{(0, i), (i, 0) : i = 1 \dots v\}$ ; see figure 1. In this case the valency of

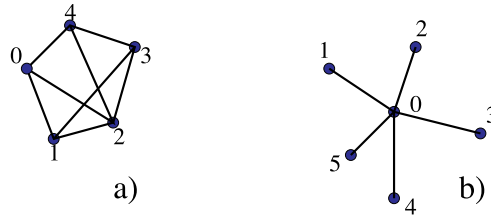

Figure 1. Examples of a graph (a) and a star graph (b).

vertex 0 is  $v$  and the valency of the other vertices is 1. This simplifies the matrix  $S$ ; for example, backscattering from the vertices  $1 \dots v$  has weight 1. We shall call such backscatterings *trivial*. As for transitions through the vertex 0, backscattering has weight  $\frac{v-2}{v}$  while normal scattering has weight  $2/v$ . It is clear that in the limit  $v \rightarrow \infty$  the leading-order contributions come from orbits with the maximum number of nontrivial backscatterings. This will form the basis of our analysis.

### 3. Expansion of the form factor

#### 3.1. General formulae

To study statistics of the spectrum we introduce the following functions. The two-point autocorrelation function is defined by

$$\begin{aligned} R_2(x) &\equiv \left(\frac{2\pi}{L}\right)^2 \left\langle d(\lambda) d\left(\lambda - \frac{2\pi x}{L}\right) \right\rangle \\ &\equiv \left(\frac{2\pi}{L}\right)^2 \lim_{\Lambda \rightarrow \infty} 1/(2\Lambda) \int_{-\Lambda}^{\Lambda} d(\lambda) d\left(\lambda - \frac{2\pi x}{L}\right) d\lambda. \end{aligned} \quad (7)$$

The form factor  $K(\tau)$  is the Fourier transform of the autocorrelation function

$$K(\tau) = \int_{-\infty}^{\infty} (R_2(x) - 1) \exp(2\pi i x \tau) dx. \quad (8)$$

Inserting the trace formula (6) into the definition of the autocorrelation function and performing the Fourier transform we obtain

$$K(\tau) = \frac{1}{L^2} \sum_{n=2}^{\infty} \sum_{p, q \in \tilde{P}_n} \frac{l_p l_q}{r_p r_q} A_p A_q \delta\left(\tau - \frac{l_p}{L}\right) \delta_{l_p, l_q} \quad (9)$$

when  $\tau > 0$  ( $K$  is an even function). Loosely speaking, the form factor is a sum of delta functions positioned at the lengths of the periodic orbits and weighted by the factors  $A_p$ . Note the coupling between different orbits of the same length which is present due to the Kronecker delta. We will refer to classes of orbits of the same length as *degeneracy classes*. The condition that the individual lengths of the edges are incommensurate implies that for two orbits to have the same length they have to traverse the *same set of edges*<sup>†</sup> although in a different order. As a consequence, all orbits in a degeneracy class have the same period. This allows us to write

$$K(\tau) = \frac{1}{L^2} \sum_{n=2}^{\infty} \sum_{\ell} \ell^2 \delta\left(\tau - \frac{\ell}{L}\right) \left( \sum_{p \in \tilde{P}_n, l_p = \ell} \frac{A_p}{r_p} \right)^2 \quad (10)$$

<sup>†</sup> Or, rather, the same *multiset* of edges, because the number of traversals of each edge is what is important here.

where the first (outmost) sum is over all periods, the second is over all degeneracy classes, characterized by the length  $\ell$  of their orbits, and the last is over the orbits within a given degeneracy class.

In what follows we assume that the individual lengths of the edges are densely distributed around their average, which, without loss of generality, we take to be unity; for example, they might have uniform distribution on the interval  $[1 - 1/(2v), 1 + 1/(2v)]$  in such a way that  $L = 2v$ . Note that the distribution changes with the valency  $v$ . This is done in such a way that the orbits of period  $2k$  (in star graphs all periods are even) have their lengths distributed in the interval  $[2k - k/v, 2k + k/v]$  and, therefore, when  $k/v < 1$  the corresponding delta functions are concentrated in the interval

$$\left[ \frac{k}{v} - \frac{k}{2v^2}, \frac{k}{v} + \frac{k}{2v^2} \right] \subset \left[ \frac{k}{v} - \frac{1}{2v}, \frac{k}{v} + \frac{1}{2v} \right]. \quad (11)$$

Thus, for  $\tau = k/v < 1$ , the contribution from orbits of different period will be confined to nonintersecting intervals. To approximate the form factor around  $k/v$  we integrate it against the characteristic function of the corresponding interval and divide by the length  $1/v$  of the interval. This contribution is equal to

$$\tilde{K}(\tau) = \lim_{v \rightarrow \infty} \frac{v}{L^2} \sum_{\ell} \ell^2 \left( \sum_{p \in \widetilde{P}_{2k}, l_p = \ell} \frac{A_p}{r_p} \right)^2 \quad (12)$$

where  $\tau = k/v$ . It is clear that  $\tilde{K}(\tau)$  is the weak limit of  $K(\tau)$  in the generalized sense as  $v \rightarrow \infty$ .

Under the above conditions on the distribution of the lengths, the form factor  $K(k/v)$  is well approximated by another quantity,  $\langle |\text{Tr } \mathbf{S}^{2k}|^2 \rangle / (2L)$ , the periodic orbit expansion for which can be obtained from (12) by substituting  $\ell = 2k$ . In what follows we make the approximation  $\ell \approx 2k$  (i.e. consider  $\langle |\text{Tr } \mathbf{S}^{2k}|^2 \rangle / (2L)$  instead of  $K(k/v)$ ) but still refer to the resulting expression as the form factor.

We start by dividing all orbits into  $v$  groups, based on the number  $j$  of *different* edges the orbit traverses. This number is an invariant of the degeneracy class; thus the sums over the degeneracy classes will remain intact. In every degeneracy class the leading-order contribution comes from the orbits with the maximum number of backscatterings from the central vertex; that is, from the orbits with  $k - j$  nontrivial backscatterings (for an example, see section 3.4). Our approach will be to extract this contribution and regroup the remaining orbits based on how many backscatterings short of the maximum they are. Thus we write

$$\tilde{K}(\tau) = K_1(\tau) + \lim_{v \rightarrow \infty} \frac{v}{L^2} \sum_{j=2}^{\infty} (2k)^2 \binom{v}{j} \left( \frac{2}{v} \right)^{2j} \left( \frac{v-2}{v} \right)^{2k-2j} D_j(v) = \sum_{j=1}^{\infty} K_j(\tau) \quad (13)$$

where

- $K_1(\tau)$  is the contribution from the orbits that are confined to one edge. This term will be treated separately.
- $L = 2v$  is the total length of the graph,
- $(2k)^2$  is the approximate squared length of the orbits,
- the binomial coefficient is the number of ways to choose  $j$  traversed edges out of the available  $v$ ,
- $\left( \frac{2}{v} \right)^{2j} \left( \frac{v-2}{v} \right)^{2k-2j}$  is the factor  $A_p^2$  for an orbit which traverses  $j$  different edges and has the maximum number of backscatterings,  $k - j$ ,

• and

$$D_j(v) = \sum_{\substack{(s_1, \dots, s_j) \\ \sum s_i = k}} D_{(s_1, \dots, s_j)}^2(v) \tag{14}$$

is the sum of the contributions  $D_{(s_1, \dots, s_j)}(v)$  of the degeneracy classes, with  $s_i$  being the number of the traversings of the edge  $i$  by an orbit from a particular class. Here we count the traversals in one direction only, e.g. the traversals from the centre to periphery.

We now have that

$$D_{(s_1, \dots, s_j)}(v) = \sum_{m=0}^{k-j} \left(\frac{2}{v}\right)^m \left(\frac{2-v}{v}\right)^{-m} Q_m(j) = \sum_{m=0}^{k-j} \left(\frac{-2}{v-2}\right)^m Q_m(j) \tag{15}$$

where  $Q_m(j)$  represents how many orbits with  $k - j - m$  backscatterings (that is,  $m$  less than the maximum) there are in this degeneracy class. Here we have ignored the influence of repetitions, on the grounds that these give an exponentially subdominant contribution.

Taking the limit as  $v \rightarrow \infty$  in (13) termwise and with  $\tau = k/v$  fixed, we find

$$\tilde{K}(\tau) = K_1(\tau) + \sum_{j=2}^{\infty} \frac{4^j}{j!} D_j \tau^2 \exp(-4\tau) \tag{16}$$

where  $D_j = \lim_{v \rightarrow \infty} v^{1-j} D_j(v)$ .

### 3.2. Calculation of $K_1(\tau)$

$K_1(\tau)$  is the contribution from orbits which are confined to only one edge. All factors in  $K_1(\tau)$  are the same as for general  $j$ , with the exception that we take into account the repetitions. Or, rather, we cannot afford to ignore them, because in this case all contributing orbits are just pure repetitions with  $r_p = k$ . There are no degeneracies, therefore

$$K_1(\tau) = \lim_{v \rightarrow \infty} \frac{v}{L^2} 2^2 v \left(\frac{v-2}{v}\right)^{2k} = \lim_{v \rightarrow \infty} \left(1 - \frac{1}{v/2}\right)^{4\tau v/2} \tag{17}$$

and so, taking the limit while holding  $\tau$  fixed,

$$K_1(\tau) = \exp(-4\tau). \tag{18}$$

### 3.3. The $j = 2$ contribution

The  $j = 2$  contribution is relatively simple and can be considered separately to illustrate our approach. It has the form

$$K_2(\tau) = \frac{4^2}{2!} \tau^2 \exp(-4\tau) D_2 \tag{19}$$

where  $D_2 = \lim_{v \rightarrow \infty} \frac{D_2(v)}{v}$ . We now use the fact that as  $v \rightarrow \infty$  the sum in  $D_2(v)$  can be replaced by an integral, so

$$D_2(v) \approx v \int_0^\tau D^2(q_1, \tau - q_1) dq_1 \tag{20}$$

where  $D(q_1, q_2)$  is the  $v \rightarrow \infty$  limit of  $D_{(s_1, s_2)}(v)$ , the contribution from orbits which traverse only two edges  $s_1$  and  $s_2$  times respectively, and  $q_i = s_i/v$ .  $D_{(s_1, s_2)}(v)$  can be expanded as

$$\begin{aligned} D_{(s_1, s_2)}(v) &\approx 1 + \frac{1}{2} P_2^{s_1} P_2^{s_2} \left(\frac{2}{v-2}\right)^2 + \frac{1}{3} P_3^{s_1} P_3^{s_2} \left(\frac{2}{v-2}\right)^4 + \dots \\ &= \sum_{m=0}^{\infty} \frac{1}{m+1} P_{m+1}^{s_1} P_{m+1}^{s_2} \left(\frac{2}{v-2}\right)^{2m} \end{aligned} \tag{21}$$

where  $P_g^s = \binom{s-1}{g-1}$  is the number of partitions of an interval of length  $s$  into  $g$  nonintersecting subintervals of integer length. The idea of the decomposition is based on the fact that a  $j = 2$  orbit may be represented in general as

$$(1, \dots, 1, \overbrace{2, \dots, 2}^{b_0}, \overbrace{1, \dots, 1}^{a_1}, \dots, \overbrace{1, \dots, 1}^{a_m}, \overbrace{2, \dots, 2}^{b_m}) \quad (22)$$

corresponding to  $a_0$  traversals of the first edge, then  $b_0$  traversals of the second, then another  $a_1$  of the first, and so on. The sum  $\sum_{i=0}^m a_i$  is equal to  $s_1$  and  $\sum_{i=0}^m b_i = s_2$ . In the general term in (21),  $P_{m+1}^{s_1}$  is the number of ways to decompose  $s_1$  into a sum of  $a_i$ ,  $P_{m+1}^{s_2}$  is the number of ways to decompose  $s_2$  into a sum of  $b_i$  multiplied by the weight factor ( $2m$  backscatterings less than the maximum possible number  $k - 2$ ) and divided by  $m + 1$ , which, again ignoring repetitions, corresponds approximately to the cyclic symmetry. This approximation is the only one in (21). When compared with (15),  $Q_{2m}(2) = \frac{1}{m+1} P_{m+1}^{s_1} P_{m+1}^{s_2}$  and  $Q_{2m+1}(2) = 0$ .

Taking the limit  $v \rightarrow \infty$  termwise, we obtain

$$\begin{aligned} D(q_1, q_2) &= 1 + \frac{1}{2} q_1 q_2 2^2 + \frac{1}{3} \frac{1}{2!} q_1^2 \frac{1}{2!} q_2^2 2^4 + \dots \\ &= \sum_{m=0}^{\infty} \frac{(4q_1 q_2)^m}{m!(m+1)!} = \frac{I_1(4\sqrt{q_1 q_2})}{2\sqrt{q_1 q_2}} \end{aligned} \quad (23)$$

where  $q_1 = s_1/v$ ,  $q_2 = s_2/v$  and  $I_1(x)$  is a Bessel function, and so, using the substitution  $q_1 = (\tau + \tau \cos \phi)/2$  we evaluate

$$\begin{aligned} \lim_{v \rightarrow \infty} D_2(v)/v &= \int_0^\tau \frac{I_1^2(4\sqrt{q_1(\tau - q_1)})}{4q_1(\tau - q_1)} dq_1 = \frac{1}{2\tau} \int_0^\pi \frac{I_1^2(2\tau \sin \phi)}{\sin \phi} d\phi \\ &= \frac{1}{4\tau^2} (I_1(4\tau) - 2\tau). \end{aligned} \quad (24)$$

Thus,

$$K_2(\tau) = 2 \exp(-4\tau) (I_1(4\tau) - 2\tau). \quad (25)$$

### 3.4. $K_j(\tau)$ for general $j$

We now proceed to calculate the degeneracy factor  $D_{(s_1, \dots, s_j)}(v)$  of (15) for general  $j$ . We begin with some examples for  $j = 3$ :

- the orbit  $(1, 1, 1, 3, 3, 2, 2, 2, 2)$  has the maximum number of backscatterings and therefore will be counted in  $Q_0(3)$ .
- the orbit  $(1, 1, 3, 3, 1, 2, 2, 2, 2)$  is one backscattering short of the maximum number and will be counted in  $Q_1(3)$ .
- the orbit  $(1, 1, 2, 2, 3, 3, 2, 1, 2)$  is three backscatterings short of the maximum number, and so belongs to  $Q_3(3)$ .

The orbits from  $Q_0(j)$  are the simplest. They achieve the maximum number of the backscatterings and consist of  $j$  blocks of edges, like the orbit in the first example above. There are  $(j - 1)!$  different orbits in  $Q_0(j)$  ( $j!$  permutations divided by  $j$  due to the cyclic symmetry).

The structure of the orbits in  $Q_1(j)$  is as follows. We take an orbit from  $Q_0$ , for example the orbit  $(1 \dots 1, 2 \dots 2, \dots, j \dots j)$ , partition one of the  $j$  blocks of edges into two blocks and permute the resulting  $j + 1$  blocks, obtaining  $j!$  variants. For example, take the block of 1's of the orbit

$$(1, 1, 1, 1, 1, 2, 2, 3, 3, 3) \quad (26)$$

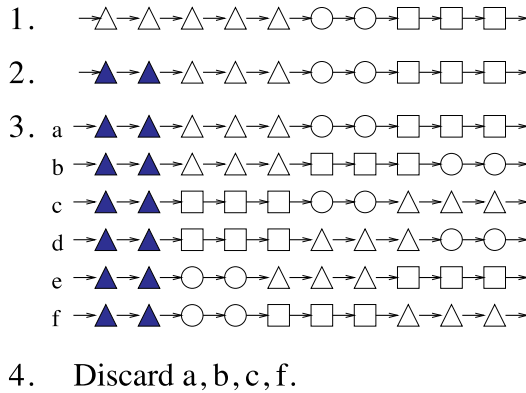

**Figure 2.** Obtaining the orbits from  $Q_1(3)$ . Different shapes correspond to different edges. First we choose an orbit from  $Q_0(3)$ , then partition the block of triangles into two parts (indicated by the filling), and then we permute the resulting four blocks, getting six orbits. Finally, we discard those which have blocks of triangles standing next to each other. The orbits (c) and (f) are discarded due to the cyclic symmetry.

divide it into two blocks,  $A_1 = (1, 1)$  and  $A_2 = (1, 1, 1)$  and permute with the others, resulting in  $j! = 6$  variants, see figure 2. However, one has to take care of the permutations where the blocks  $A_1$  and  $A_2$  stand next to each other, because such orbits belong to  $Q_0(j)$ . Of these there are  $(j - 1)!$  permutations with  $A_1$  standing immediately after  $A_2$  plus  $(j - 1)!$  permutations with  $A_1$  standing in front. Thus the resulting number is  $j! - 2(j - 1)!$ . This is multiplied by  $P_2^{s_1}/2!$ , the number of partitions<sup>†</sup> of the block of 1's.

Finally, taking into account that we can also partition the blocks of other edges, we arrive at

$$Q_1(j) = (j! - 2(j - 1)!) \sum_{i=1}^j \frac{1}{2} P_2^{s_i}. \tag{27}$$

Applying a similar algorithm for  $Q_2(j)$  we note that there are two types of orbit in this case. The first is obtained by partitioning one block into three and permuting with the other blocks, while the second is obtained by partitioning two blocks, each into two parts. The result is

$$Q_2(j) = ((j + 1)! - 6j! + 6(j - 1)!) \sum_{i=1}^j \frac{1}{3!} P_3^{s_i} + ((j + 1)! - 4j! + 4(j - 1)!) \sum_{\substack{i,k=1 \\ i \neq k}}^j \frac{1}{2} P_2^{s_i} \frac{1}{2} P_2^{s_k}. \tag{28}$$

While it is easy to predict that the general formula for  $Q_i(j)$  takes the form

$$Q_m(j) = \sum_{\substack{g_1, \dots, g_j \\ G=m+j}} P_{(g_1, \dots, g_j)}(j) \prod_{i=1}^j \frac{P^{s_i}}{g_i!} \tag{29}$$

where  $g_i \geq 1$  is the number of partitions of the  $i$ th block and  $G = \sum_{i=1}^j g_i$ , it is not so easy to calculate the polynomials  $P_{(g_1, \dots, g_j)}(j)$ . The general combinatorial question can be formulated as follows: we have  $G = \sum_{i=1}^j g_i$  objects of  $j$  different types ( $g_i$  objects of type  $i$ , etc). How

<sup>†</sup> We refer to partitions of the integer  $s$  into  $k = 2$  non-zero summands, modulo permutation of the summands. For example, the partitions  $2 + 3$  and  $3 + 2$  are counted as one. The number of such partitions is approximated by its first-order asymptotic as  $s \rightarrow \infty$ , namely  $P_k^s/k!$ . Note that in what follows we take the limit  $v \rightarrow \infty$  termwise, which corresponds to the limit  $s \rightarrow \infty$ .

many permutations of these objects are there without any objects of the same type standing next to each other? This question is studied in the appendix. The answer is

$$P_{(g_1, \dots, g_j)}(j) = (-1)^{G-j} \sum_{N=0}^{\infty} (-1)^N \frac{\partial^{j-1+N}}{\partial x^{j-1+N}} \left[ \frac{1}{x} \prod_{i=1}^j h_{g_i}(x) \right] \Big|_{x=0} \tag{30}$$

where

$$h_g(x) = \sum_{s=1}^g \binom{g-1}{g-s} \frac{g!}{s!} x^s. \tag{31}$$

Going back to  $D_{(s_1, \dots, s_j)}(v)$  we obtain

$$\begin{aligned} D_{(s_1, \dots, s_j)}(v) &= \sum_{m=0}^{k-j} \left( \frac{-2}{v-2} \right)^m Q_m(j) \\ &= \sum_{m=0}^{k-j} \sum_{\substack{g_1, \dots, g_j \\ G=m+j}} \left( \frac{2}{v-2} \right)^m \sum_{N=0}^{\infty} (-1)^N \frac{\partial^{j-1+N}}{\partial x^{j-1+N}} \left[ \frac{1}{x} \prod_{i=1}^j \frac{P_{g_i}^{s_i}}{g_i!} h_{g_i}(x) \right] \Big|_{x=0} \\ &= \sum_{N=0}^{\infty} (-1)^N \frac{\partial^{j-1+N}}{\partial x^{j-1+N}} \left[ \frac{1}{x} \sum_{m=0}^{k-j} \sum_{\substack{g_1, \dots, g_j \\ G=m+j}} \prod_{i=1}^j \left( \frac{2}{v-2} \right)^{g_i-1} \frac{P_{g_i}^{s_i}}{g_i!} h_{g_i}(x) \right] \Big|_{x=0} \\ &= \sum_{N=0}^{\infty} (-1)^N \frac{\partial^{j-1+N}}{\partial x^{j-1+N}} \left[ \frac{1}{x} \prod_{i=1}^j \left( \sum_{g_i=1}^{\infty} \left( \frac{2}{v-2} \right)^{g_i-1} \frac{P_{g_i}^{s_i}}{g_i!} h_{g_i}(x) \right) \right] \Big|_{x=0} \end{aligned} \tag{32}$$

where  $P_g^s = \binom{s-1}{g-1}$  and the limit of the innermost sum has been extended to infinity since  $P_g^s = 0$  for  $g > s$ . Taking the limit  $v \rightarrow \infty$  termwise, again with  $s_i/v = q_i$  fixed, gives

$$D(q_1, \dots, q_j) = \sum_{N=0}^{\infty} (-1)^N \frac{\partial^{N+j-1}}{\partial x^{N+j-1}} \left[ \frac{1}{x} \prod_{i=1}^j \left( \sum_{g_i=1}^{\infty} \frac{(2q_i)^{g_i-1}}{(g_i-1)!g_i!} h_{g_i}(x) \right) \right] \Big|_{x=0}. \tag{33}$$

Now expanding the functions  $h_{g_i}(x)$  and resumming the series

$$\begin{aligned} \prod_{i=1}^j \left( \sum_{g_i=1}^{\infty} \frac{(2q_i)^{g_i-1}}{(g_i-1)!g_i!} h_{g_i}(x) \right) &= \prod_{i=1}^j \left( \sum_{g_i=1}^{\infty} \sum_{s=1}^{g_i} \frac{(2q_i)^{g_i-1}}{(g_i-1)!g_i!} \binom{g_i-1}{g_i-s} \frac{g_i!}{s!} x^s \right) \\ &= \prod_{i=1}^j \left( \sum_{s=1}^{\infty} \frac{x^s}{s!(s-1)!} \sum_{g_i=s}^{\infty} \frac{(2q_i)^{g_i-1}}{(g_i-s)!} \right) \\ &= \prod_{i=1}^j \left( x \sum_{s=1}^{\infty} \frac{(2xq_i)^{s-1}}{s!(s-1)!} \sum_{g_i=s}^{\infty} \frac{(2q_i)^{g_i-s}}{(g_i-s)!} \right) \\ &= \prod_{i=1}^j \left( x \exp(2q_i) \sum_{s=1}^{\infty} \frac{(2xq_i)^{s-1}}{s!(s-1)!} \right) \\ &= x^j \exp(2\tau) \prod_{i=1}^j R(2xq_i) \end{aligned} \tag{34}$$

where  $R(y) = y^{-1/2} I_1(2\sqrt{y}) = \sum_{i=0}^{\infty} \frac{y^i}{i!(i+1)!}$  and  $\tau = \sum_{i=1}^j q_i = k/v$ , as before. Thus we obtain

$$D(q_1, \dots, q_j) = \exp(2\tau) \sum_{N=0}^{\infty} (-1)^N \frac{\partial^{N+j-1}}{\partial x^{N+j-1}} \left[ x^{j-1} \prod_{i=1}^j R(2xq_i) \right] \Big|_{x=0}. \tag{35}$$



For derivatives of the function  $R(2xq_i)$  one has

$$\frac{\partial^n}{\partial x^n} R(2xq_i) \Big|_{x=0} = \frac{(2q_i)^n}{(n+1)!} \quad \text{and} \quad \frac{\partial^{n+1}}{\partial x^{n+1}} x R(2xq_i) \Big|_{x=0} = \frac{(2q_i)^n}{n!} \tag{36}$$

therefore, in (35),

$$\begin{aligned} & \sum_{N=0}^{\infty} (-1)^N \frac{\partial^{N+j-1}}{\partial x^{N+j-1}} \left[ x^{j-1} \prod_{i=1}^j R(2xq_i) \right] \Big|_{x=0} \\ &= \sum_{N=0}^{\infty} (-1)^N 2^N \sum_{n_1+\dots+n_j=N} (N+j-1)! \prod_{i=1}^j \frac{q_i^{n_i}}{n_i!(n_i+1)!} \end{aligned} \tag{37}$$

where the second sum is performed over  $j$  variables  $n_1, \dots, n_j$  and the rule

$$\begin{aligned} & \frac{\partial^{N+j-1}}{\partial x^{N+j-1}} \prod_{i=1}^j x^{j-1} f_i(x) \\ &= \sum_{n_1+\dots+n_j=N} (N+j-1)! \frac{1}{n_1!} \frac{\partial^{n_1}}{\partial x^{n_1}} f_1(x) \prod_{i=2}^j \frac{1}{(n_i+1)!} \frac{\partial^{n_i+1}}{\partial x^{n_i+1}} x f_i(x) \end{aligned} \tag{38}$$

was used. Thus we arrive at

$$D(q_1, \dots, q_j) = \exp(2\tau) \sum_{n_1+\dots+n_j=0}^{\infty} (-1)^N 2^N (N+j-1)! \prod_{i=1}^j \frac{q_i^{n_i}}{n_i!(n_i+1)!} \tag{39}$$

where  $N = \sum_{i=1}^j n_i$ . Using the fact, once again, that as  $v \rightarrow \infty$  the summation in (14) can be replaced by the integral

$$D_j = \int_{\sum_{i=1}^j q_i = \tau} D^2(q_1, \dots, q_j) dq_1 \dots dq_{j-1} \tag{40}$$

and applying the rule

$$\int_{\sum_{i=1}^j q_i = \tau} q_1^{m_1} \dots q_j^{m_j} dq_1 \dots dq_{j-1} = \frac{m_1! \dots m_j!}{(M+j-1)!} \tau^{M+j-1} \tag{41}$$

where  $M = \sum_{i=1}^j m_i$ , gives

$$\begin{aligned} D_j &= \exp(4\tau) \sum_{\substack{k_1+\dots+k_j=0 \\ n_1+\dots+n_j=0}}^{\infty} (-2)^{N+K} \tau^{N+K+j-1} \frac{(N+j-1)!(K+j-1)!}{(N+K+j-1)!} \\ &\times \prod_{i=1}^j \frac{(n_i+k_i)!}{n_i!k_i!(n_i+1)!(k_i+1)!} \end{aligned} \tag{42}$$

where  $K = \sum_{i=1}^j k_i$  and  $N = \sum_{i=1}^j n_i$ . Therefore, the final result for  $K_j(\tau)$  is

$$K_j(\tau) = \frac{4^j}{j!} \sum_{M=0}^{\infty} C_M \tau^{M+j+1} \tag{43}$$

and so

$$K(\tau) = K_1(\tau) + \sum_{j=2}^{\infty} \sum_{M=0}^{\infty} \frac{4^j}{j!} C_M \tau^{M+j+1} \tag{44}$$

where

$$C_M = (-2)^M \sum_{k_1+\dots+k_j+n_1+\dots+n_j=M} \frac{(K+j-1)!(N+j-1)!}{(M+j-1)!} \prod_{i=1}^j \frac{\binom{n_i+k_i}{n_i}}{(n_i+1)!(k_i+1)!} \quad (45)$$

with  $K = \sum_{i=1}^j k_i$ ,  $N = \sum_{i=1}^j n_i$ , and the sum being performed over the  $2j$  variables  $k_i$  and  $n_i$ .

This is our main result. It constitutes a general formula for computing the coefficients in the expansion of  $K(\tau)$  for star graphs in powers of  $\tau$  around  $\tau = 0$ . Note that as  $\tau \rightarrow 0$ , the sum in (44) tends to zero as  $\tau^3$ , and so it follows from (18) that  $K(\tau) \rightarrow 1$  in this limit. This is the same as for the Poisson form factor, and unlike the random-matrix results, which all tend to zero linearly in  $\tau$ . However, the Poisson form factor is independent of  $\tau$ , and  $K(\tau)$  here clearly is not: after an initial decrease as  $\tau$  increases, it eventually rises to a limiting value of one. In this sense, the result is intermediate between the Poisson and random-matrix forms.

The expression for  $C_M$  can be written in another form that is more suitable for computation. Defining

$$F_1(K, N) = \frac{\binom{K+N}{N}}{(N+1)!(K+1)!} \quad (46)$$

and using

$$\begin{aligned} & \sum_{k_1+\dots+k_j+n_1+\dots+n_j=M} \frac{(K+j-1)!(N+j-1)!}{(M+j-1)!} \prod_{i=1}^j \frac{\binom{n_i+k_i}{n_i}}{(n_i+1)!(k_i+1)!} \\ &= \sum_{K+N=M} \frac{(K+j-1)!(N+j-1)!}{(M+j-1)!} \sum_{\substack{k_1+\dots+k_j=K \\ n_1+\dots+n_j=N}} \prod_{i=1}^j \frac{\binom{n_i+k_i}{n_i}}{(n_i+1)!(k_i+1)!} \end{aligned} \quad (47)$$

it follows that

$$C_M = (-2)^M \sum_{K=0}^M \frac{(K+j-1)!(M-K+j-1)!}{(M+j-1)!} F_j(K, M-K) \quad (48)$$

where

$$F_j(K, N) = \sum_{k=0}^K \sum_{n=0}^N F_1(k, n) F_{j-1}(K-k, N-n) \quad (49)$$

which is a form of convolution. Expression (48) for the coefficients  $C_M$  is computationally more convenient because there is a clear recursive relation for the coefficients  $F_j(K, N)$  which can be facilitated using the discrete Fourier transform. The results of numerical computations with the first few coefficients of the expansion are shown in figure 3.

#### 4. A summable approximation

One possible approximation to  $\tilde{K}(\tau)$  can be made by ignoring two contributions:

- (1) the off-diagonal terms in (9). We call a term in the summation in (9) diagonal if it corresponds to  $\mathbf{p} = \mathbf{q}$ , otherwise we call it off-diagonal. In symbolic form, the diagonal approximation is

$$K(\tau) \approx K^{\text{diag}}(\tau) = \frac{1}{L^2} \sum_{n=2}^{\infty} \sum_{\mathbf{p} \in \tilde{P}_n} \left( \frac{l_{\mathbf{p}}}{r_{\mathbf{p}}} \right)^2 A_{\mathbf{p}}^2 \delta \left( \tau - \frac{l_{\mathbf{p}}}{L} \right). \quad (50)$$

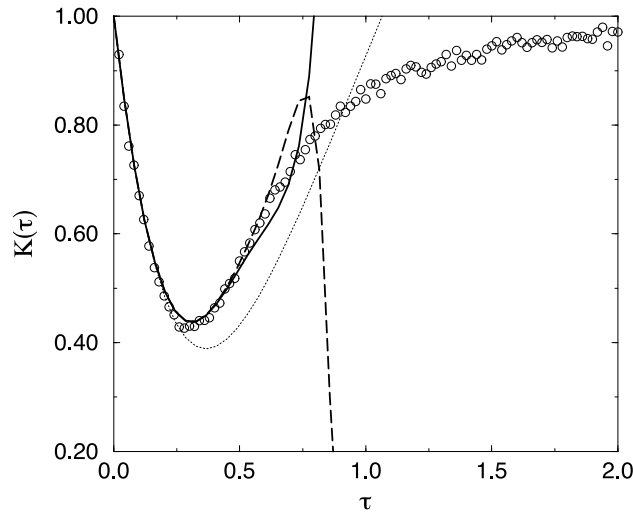

**Figure 3.** The first 11 terms (solid curve) and the first seven terms (dashed curve) in the expansion for  $K(\tau)$ , compared with data from the numerical simulation by Kottos and Smilansky [5] for  $(|\text{Tr } S^{2k}|^2)/(4v)$ ,  $v = 50$  (circles). The dotted curve corresponds to the diagonal approximation (52).

- (2) all orbits for which the number of backscatterings is less than the maximum in their degeneracy class. For example, the orbits (1, 1, 4, 6, 6, 6) and (1, 1, 6, 4, 6, 6) belong to the same degeneracy class. The first orbit has three nontrivial backscatterings which is the maximum for this class; therefore its contribution will be counted while the second orbit will be ignored. It is not hard to see that out of each degeneracy class only  $(j - 1)!$  orbits will survive this approximation, where  $j$ , as before, is the number of distinct edges traversed by the orbit.

The result of the above approximations is that the contribution of the degeneracy classes in (13) is reduced to a factor of  $(j - 1)!$ , the contribution of one degeneracy class, multiplied by the number of degeneracy classes,  $\binom{k-1}{j-1}$ :

$$K^{\text{diag}}(\tau) \approx K_1(\tau) + \lim_{v \rightarrow \infty} \frac{(2k)^2 v}{L^2} \sum_{j=2}^{\infty} \binom{v}{j} \left(\frac{2}{v}\right)^{2j} \left(\frac{v-2}{v}\right)^{2k-2j} (j-1)! \binom{k-1}{j-1}. \quad (51)$$

Taking the limit as  $v \rightarrow \infty$  termwise, with  $\tau = k/v$  fixed, we arrive at

$$\begin{aligned} K^{\text{diag}}(\tau) &\approx K_1(\tau) + \tau^2 \sum_{j=2}^{\infty} 2^{2j} \exp(-4\tau) \frac{\tau^{j-1}}{j!} \\ &= \exp(-4\tau) + \tau \exp(-4\tau) \sum_{j=2}^{\infty} \frac{(4\tau)^j}{j!} \\ &= \exp(-4\tau) + \tau - \tau \exp(-4\tau)(4\tau + 1) \\ &= \tau + \exp(-4\tau)(1 - \tau - 4\tau^2) \end{aligned} \quad (52)$$

which, in the limit of large  $v$  with  $\tau = k/v$  fixed, is exactly equal to an approximation to  $(|\text{Tr } S^{2k}|^2)/(4v)$  obtained in [5] using a different approach. Interestingly, the first four terms in the expansion of  $K^{\text{diag}}$  in powers of  $\tau$  agree with those of  $K$  computed in the last section. The rest do not.

It is worth remarking that one can get exactly the same asymptotic formula for  $K^{\text{diag}}(\tau)$  using only assumption (1). Following [5], we obtain from (50) ( $n = 2k$ )

$$\begin{aligned} K^{\text{diag}}(\tau) &= \lim_{v \rightarrow \infty} \frac{4kv}{L^2} \sum_{p \in \widetilde{P}_{2k}} \frac{k}{r_p^2} A_p^2 \\ &\approx K_1(\tau) + \lim_{v \rightarrow \infty} \frac{4kv}{L^2} \left( \sum_{p \in \widetilde{P}_{2k}} \frac{k}{r_p} A_p^2 - v \left( \frac{v-2}{v} \right)^{2k} \right) \end{aligned} \quad (53)$$

where we have split  $K^{\text{diag}}(\tau)$  into  $K_1(\tau)$  and ‘the rest’, as before, partly ignored the repetitions and are now going to evaluate ‘the rest’ using a sum rule. We note that  $\sum_{p \in \widetilde{P}_{2k}} \frac{k}{r_p} A_p^2 = \text{Tr } A^k$ , where the matrix  $A$  is given by

$$A_{e_1, e_2} = S_{e_1, e_2}^2 \quad (54)$$

with  $S$  the matrix defined by (5). The  $v \times v$  matrix  $A$  has the eigenvalues  $\{1, \frac{v-4}{v}, \dots, \frac{v-4}{v}\}$  and, therefore,

$$\text{Tr } A^k = 1 + (v-1) \left( \frac{v-4}{v} \right)^k. \quad (55)$$

Using this we write

$$K^{\text{diag}}(\tau) \approx K_1(\tau) + \lim_{v \rightarrow \infty} \tau \left( 1 + (v-1) \left( \frac{v-4}{v} \right)^k - v \left( \frac{v-2}{v} \right)^{2k} \right) \quad (56)$$

$$\begin{aligned} &= K_1(\tau) + \lim_{v \rightarrow \infty} \tau \left( 1 - \left( \frac{v-4}{v} \right)^k + v \left\{ \left( \frac{v-4}{v} \right)^k - \left( \frac{v-2}{v} \right)^{2k} \right\} \right) \\ &= \exp(-4\tau) + \tau (1 - \exp(-4\tau) - 4\tau \exp(-4\tau)) \end{aligned} \quad (57)$$

which is exactly the same as before. This means that the orbits ignored in the second assumption above do not contribute to the diagonal approximation in the limit  $v \rightarrow \infty$ . The fact that they do contribute to the full expansion of  $K(\tau)$  shows the limitations of the diagonal approximation.

### Acknowledgments

We are grateful to Dr H Schanz for a number of helpful discussions, to Dr T Kottos and Professor U Smilansky for permission to use their data in figure 3, and to Professor M V Berry for comments on an early draft of the manuscript.

### Appendix. Permutations without liaisons

We have addressed the question of how many permutations of  $G$  distinguishable objects of  $j$  different types there are, under the condition that no objects of the same type may stand next to each other. By a ‘permutation’ we mean a cyclic ordering of the objects so that, for example, the permutations (1, 2, 3, 2) and (2, 3, 2, 1) are considered to be the same.

Note that the problem as stated is purely combinatorial: in this appendix we ignore the underlying structure of the objects as blocks of edges.

If two objects of the same type stand next to each other, we say that they form a *liaison*. Since all the objects are distinguishable, the liaisons are order dependent. For example, if  $a_1$ ,  $a_2$  and  $a_3$  are objects of the same type then  $a_1 a_2$  is one liaison,  $a_2 a_1$  is a different one, and  $a_1 a_2 a_3$  is a group of two liaisons, see figure A1. The maximal possible number of liaisons is  $l_{\text{max}} = G - j$ .

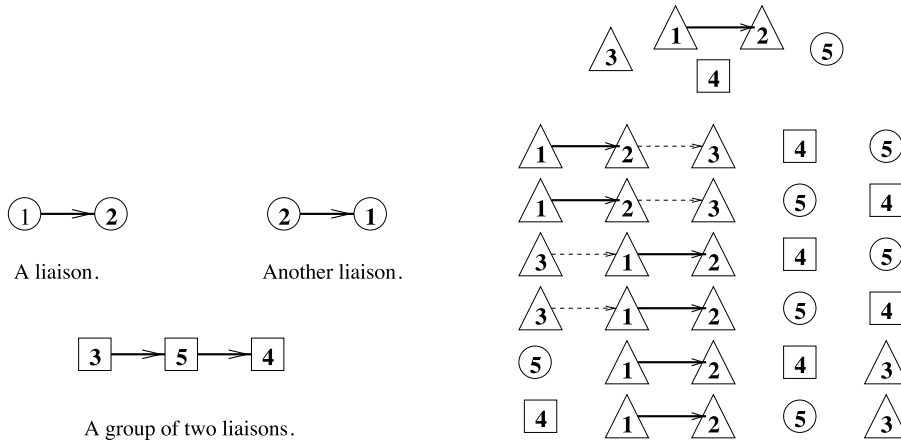

**Figure A1.** Different liaisons. The type of an object is indicated by its shape.

**Figure A2.** A collection of four objects and its six permutations. In the collection the objects 1 and 2 are counted as one since they are bound by a liaison (solid arrow). Note that in four of the permutations an additional liaison appears (dashed arrow).

The answer to our question, of course, depends on the numbers  $g_i$ , the number of objects of type  $i$ , which satisfy  $G = \sum_{i=1}^j g_i$ . We derive the answer in four stages.

*Stage 1.* To count the permutations without liaisons we apply an analogue of the inclusion-exclusion principle. Fix  $l$  liaisons. Any objects bound by liaison(s) are considered to be one object now. Permuting the resulting  $G - l$  objects while imposing no restrictions apart from holding the selected liaisons fixed, we obtain  $(G - l)! / (G - l)$  permutations (the factor  $1 / (G - l)$  is due to the cyclic symmetry). Note that in some permutations the number of liaisons will be greater than the initial  $l$ ; for an example see figure A2.

Now let  $F(l)$  be the number of ways to fix  $l$  liaisons in the group of  $G$  objects. Then

$$P_{(g_1, \dots, g_j)} = \sum_{l=0}^{l_{\max}} (-1)^l F(l) (G - l - 1)! \tag{58}$$

is the number of permutations without any liaisons.

Indeed, take a permutation  $\mathcal{P}$  with  $k$  liaisons. How many times is it counted in the  $l$ th term,  $l \leq k$ , of the sum in (58)? We can obtain  $\mathcal{P}$  by fixing  $l$  liaisons out of the given  $k$  in the initial group of  $G$  objects; then  $\mathcal{P}$  will be a permutation of the resulting collection of  $G - l$  objects. Thus,  $\mathcal{P}$  is counted once in the term for  $l = 0$ ,  $\binom{k}{1}$  times in the term for  $l = 1$  (see figure A3), and, generally,  $\binom{k}{l}$  times in the  $l$ th term, where  $\binom{k}{l}$  is the number of ways to choose the subset of  $l$  liaisons from the set of  $k$ . Since

$$\sum_{i=0}^k (-1)^i \binom{k}{i} = (1 - 1)^k = \delta_{k,0} \tag{59}$$

the permutation with  $k$  liaisons is not counted in  $P_{(g_1, \dots, g_j)}$  unless  $k = 0$ .

*Stage 2.* Form the polynomial

$$P_{(g_1, \dots, g_j)}(x) = \sum_{l=0}^{l_{\max}} F(l) x^l. \tag{60}$$

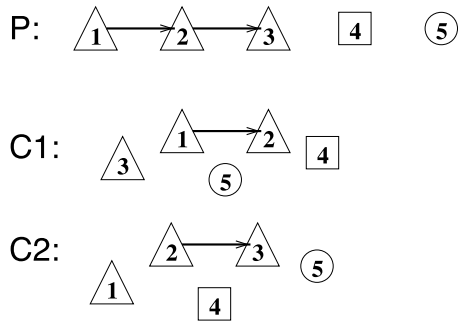

**Figure A3.** The permutation  $\mathcal{P}$  with  $k = 2$  liaisons is counted twice in the  $l = 1$  term of the sum in (58), because it can be obtained from two different collections,  $C1$  and  $C2$ , each having one liaison.

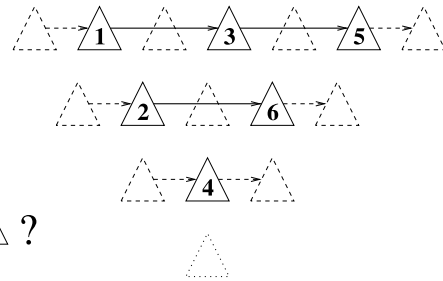

**Figure A4.** Where can we put the object number 7? We can either add it to the existing liaison chains in one of  $2g - l = 2 \times 6 - 3$  places (dashed triangles) or we can leave it free (dotted triangle). The existing liaisons are marked by solid arrows.

Then

$$P_{(g_1, \dots, g_j)}(x) = \prod_{i=1}^j P_{(1, \dots, g_i, \dots, 1)}(x) \equiv \prod_{i=1}^j P_{g_i}(x). \tag{61}$$

This decomposition follows from the fact that the number  $F_{(g_1, \dots, g_j)}(l)$  of ways to choose  $l$  liaisons is

$$F_{(g_1, \dots, g_j)}(l) = \sum_{l_1 + \dots + l_j = l} \prod_{i=0}^j F_{(1, \dots, g_i, \dots, 1)}(l_i) \equiv \sum_{l_1 + \dots + l_j = l} \prod_{i=0}^j F_{g_i}(l_i). \tag{62}$$

That is, for every decomposition  $l_1 + \dots + l_j = l$  of  $l$ , there are  $\prod_{i=0}^j F_{g_i}(l_i)$  ways to choose  $l$  liaisons in such a way that among the objects of type  $i$  we choose  $l_i$  liaisons.

The problem is now greatly reduced. We have to answer the following question: how many ways are there to choose  $l$  liaisons in a group of  $g$  objects of the same type? This number is denoted by  $F_g(l)$ .

*Stage 3.* Note that all objects are distinguishable. We derive a recursion for  $F_g(l)$  using the following reasoning. Take one of the configurations from  $F_g(l)$  and add another object to it. It can be added in two different ways: the object, numbered  $g + 1$ , can either be free or it can be engaged in a liaison. For any configuration from  $F_g(l)$  there are  $2g - l$  ways to add it in such a way that it forms a liaison; see figure A4. And, obviously, there is only one way to add a free object.

It is clear that this argument is uniquely reversible, i.e. for any configuration  $\mathcal{C}$  in  $F_{g+1}$  there is one and only one configuration in  $F_g$  from which we can obtain  $\mathcal{C}$  by adding the  $(g + 1)$ th object. Therefore, we can write the recursion

$$F_{g+1}(l + 1) = F_g(l + 1) + (2g - l)F_g(l). \tag{63}$$

The general solution, obtained using [7], is

$$F_g(l) = \binom{g - 1}{l} \frac{g!}{(g - l)!} \tag{64}$$

which can be verified by the direct substitution.

Stage 4. Now that we can compute  $P_{(g_1, \dots, g_j)}(x)$ , we need to get back to  $P_{(g_1, \dots, g_j)}$ . We use the formula

$$\begin{aligned} P_{(g_1, \dots, g_j)} &= \sum_{l=0}^{l_{\max}} (-1)^l F(l)(G-l-1)! \\ &= \sum_{l=0}^{l_{\max}} (-1)^l \frac{\partial^{G-l-1}}{\partial x^{G-l-1}} [x^{G-1} P_{(g_1, \dots, g_j)}(1/x)] \Big|_{x=0} \end{aligned} \quad (65)$$

to obtain the final solution

$$\begin{aligned} P_{(g_1, \dots, g_j)} &= \sum_{l=0}^{l_{\max}} (-1)^l \frac{\partial^{G-l-1}}{\partial x^{G-l-1}} x^{G-1} \left[ \prod_{i=1}^j \sum_{\ell_i=0}^{g_i-1} F_{g_i}(\ell_i) x^{-\ell_i} \right] \Big|_{x=0} \\ &= (-1)^{l_{\max}} \sum_{k=0}^{\infty} (-1)^k \frac{\partial^{j+k-1}}{\partial x^{j+k-1}} \left[ x^{-1} \prod_{i=1}^j \sum_{s_i=1}^{g_i} \binom{g_i-1}{g_i-s_i} \frac{g_i!}{s_i!} x^{s_i} \right] \Big|_{x=0} \end{aligned} \quad (66)$$

where the substitutions  $k = l_{\max} - l$  and  $s_i = g_i - \ell_i$  have been made and the upper limit in the first sum has been extended to infinity since all higher derivatives are equal to zero.

## References

- [1] Berry M V 1985 *Proc. R. Soc. A* **400** 229–51
- [2] Bogomolny E B and Keating J P 1996 *Phys. Rev. Lett.* **77** 1472–5
- [3] Hannay J H and Ozorio de Almeida A M 1984 *J. Phys. A: Math. Gen.* **17** 3429–40
- [4] Kottos T and Smilansky U 1997 *Phys. Rev. Lett.* **79** 4794–7
- [5] Kottos T and Smilansky U 1999 *Ann. Phys.* **274** 76–124
- [6] Schanz H and Smilansky U 1999 *Proc. Australian Summer School in Quantum Chaos and Mesoscopics (Canberra)* Preprint chao-dyn/9904007
- [7] Sloane N J A *On-line Encyclopedia of Integer Sequences* <http://www.research.att.com/~njas/sequences/>