

Mixed Statistics on 01-Fillings of Moon Polyominoes

William Y. C. Chen¹, Andrew Y. Z. Wang¹, Catherine H. Yan² and
Alina F. Y. Zhao¹

¹Center for Combinatorics, LPMC-TJKLC
Nankai University, Tianjin 300071, P. R. China

²Department of Mathematics
Texas A&M University, College Station, TX 77843, USA

Abstract

We establish a stronger symmetry between the numbers of northeast and southeast chains in the context of 01-fillings of moon polyominoes. Let \mathcal{M} be a moon polyomino with n rows and m columns. Consider all the 01-fillings of \mathcal{M} in which every row has at most one 1. We introduce four mixed statistics with respect to a bipartition of rows or columns of \mathcal{M} . More precisely, let $S \subseteq \{1, 2, \dots, n\}$ and $\mathcal{R}(S)$ be the union of rows whose indices are in S . For any filling M , the top-mixed (resp. bottom-mixed) statistic $\alpha(S; M)$ (resp. $\beta(S; M)$) is the sum of the number of northeast chains whose top (resp. bottom) cell is in $\mathcal{R}(S)$, together with the number of southeast chains whose top (resp. bottom) cell is in the complement of $\mathcal{R}(S)$. Similarly, we define the left-mixed and right-mixed statistics $\gamma(T; M)$ and $\delta(T; M)$, where T is a subset of the column index set $\{1, 2, \dots, m\}$. Let $\lambda(A; M)$ be any of these four statistics $\alpha(S; M)$, $\beta(S; M)$, $\gamma(T; M)$ and $\delta(T; M)$, we show that the joint distribution of the pair $(\lambda(A; M), \lambda(\bar{A}; M))$ is symmetric and independent of the subsets S, T . In particular, the pair of statistics $(\lambda(A; M), \lambda(\bar{A}; M))$ is equidistributed with $(\text{se}(M), \text{ne}(M))$, where $\text{se}(M)$ and $\text{ne}(M)$ are the numbers of southeast chains and northeast chains of M , respectively.

Keywords: mixed statistic, polyomino, symmetric distribution.

MSC Classification: 05A18, 05A05, 05A15

1 Introduction

Recently it is observed that the numbers of crossings and nestings have a symmetric distribution over many families of combinatorial objects, such as matchings and set partitions. Recall that a matching of $[2n] = \{1, 2, \dots, 2n\}$ is a partition of the set $[2n]$ with the property that each block has exactly two elements. It can be represented as a graph with vertices $1, 2, \dots, 2n$ drawn on a horizontal line in increasing order, where two vertices i and j are connected by an edge if and only

E-mail addresses: chen@nankai.edu.cn (W.Y.C. Chen), yezhouwang@mail.nankai.edu.cn (A.Y.Z. Wang), cyan@math.tamu.edu (C.H. Yan), zfeiyan@mail.nankai.edu.cn (A.F.Y. Zhao).

¹The first, the second, and the fourth authors were supported by the 973 Project, the PCSIRT Project of the Ministry of Education, and the National Science Foundation of China.

²The third author was supported in part by NSF grant #DMS-0653846.

if $\{i, j\}$ is a block. We say that two edges (i_1, j_1) and (i_2, j_2) form a *crossing* if $i_1 < i_2 < j_1 < j_2$; they form a *nesting* if $i_1 < i_2 < j_2 < j_1$. The symmetry of the joint distribution of crossings and nestings follows from the bijections of de Sainte-Catherine, who also found the generating functions for the number of crossings and the number of nestings. Klazar [12] further studied the distribution of crossings and nestings over the set of matchings obtained from a given matching by successfully adding edges.

The symmetry between crossings and nestings was extended by Kasraoui and Zeng [11] to set partitions, and by Chen, Wu and Yan [4] to linked set partitions. Poznanović and Yan [15] determined the distribution of crossings and nestings over the set of partitions which are identical to a given partition π when restricted to the last n elements.

Many classical results on enumerative combinatorics can be put in the larger context of counting submatrices in fillings of certain polyominoes. For example, words and permutations can be represented as 01-fillings of rectangular boards, and general graphs can be represented as \mathbb{N} -fillings of arbitrary Ferrers shapes, which were studied by Kratthenthaler [13] and de Mier [6, 7]. Other extensions include stack polyominoes [9], and moon polyominoes [16, 10]. In particular, crossings and nestings in matchings and set partitions correspond to northeast chains and southeast chains of length 2 in a filling of polyominoes. The symmetry between crossings and nestings has been extended by Kasraoui [10] to 01-fillings of moon polyominoes where either every row has at most one 1, or every column has at most one 1. In both cases, the joint distribution of the numbers of northeast and southeast chains can be expressed as a product of p, q -Gaussian coefficients. Other known statistics on fillings of moon polyominoes are the length of the longest northeast/southeast chains [2, 13, 16], and the major index [5].

The main objective of this paper is to present a stronger symmetry between the numbers of northeast and southeast chains in the context of 01-fillings of moon polyominoes. Given a bipartition of the rows (or columns) of a moon polyomino, we define four statistics by considering mixed sets of northeast and southeast chains according to the bipartition. Let M be a 01-filling of a moon polyomino \mathcal{M} with n rows and m columns. These statistics are the top-mixed and the bottom-mixed statistics $\alpha(S; M), \beta(S; M)$ with respect to a row-bipartition (S, \bar{S}) , and the left-mixed and the right-mixed statistics $\gamma(T; M), \delta(T; M)$ with respect to a column-bipartition (T, \bar{T}) . We show that for any of these four statistics $\lambda(A; M)$, namely, $\alpha(S; M), \beta(S; M)$ for $S \subseteq [n]$ and $\gamma(T; M), \delta(T; M)$ for $T \subseteq [m]$, the joint distribution of the pair $(\lambda(A; M), \lambda(\bar{A}; M))$ is symmetric and independent of the subsets S, T . Consequently, we have the equidistribution

$$\sum_M p^{\lambda(A; M)} q^{\lambda(\bar{A}; M)} = \sum_M p^{\text{se}(M)} q^{\text{ne}(M)},$$

where M ranges over all 01-fillings of \mathcal{M} with the property that either every row has at most one 1, or every column has at most one 1, and $\text{se}(M)$ and $\text{ne}(M)$ are the numbers of southeast and northeast chains of M , respectively.

The paper is organized as follows. Section 2 contains necessary notation and the statements of the main results. In Section 3, we explain how our results specialize to classical combinatorial objects, including permutations, words, matchings, and set partitions. We present the proofs of the main theorems in Section 4. In Section 5, we show by bijections that these new statistics are invariant under a permutation of columns or rows on moon polyominoes.

2 Notation and the Main Results

A *polyomino* is a finite subset of \mathbb{Z}^2 , where every element of \mathbb{Z}^2 is represented by a square cell. The polyomino is *convex* if its intersection with any column or row is connected. It is *intersection-free* if every two columns are comparable, i.e., the row-coordinates of one column form a subset of those of the other column. Equivalently, it is intersection-free if every two rows are comparable. A *moon polyomino* is a convex and intersection-free polyomino.

Given a moon polyomino \mathcal{M} , we assign 0 or 1 to each cell of \mathcal{M} so that there is at most one 1 in each row. Throughout this paper we will simply use the term *filling* to denote such 01-fillings. We say that a cell is empty if it is assigned 0, and it is a 1-cell otherwise. Assume \mathcal{M} has n rows and m columns. We label the rows R_1, \dots, R_n from top to bottom, and the columns C_1, \dots, C_m from left to right. Let $\mathbf{e} = (\varepsilon_1, \dots, \varepsilon_n) \in \{0, 1\}^n$ and $\mathbf{s} = (s_1, \dots, s_m) \in \mathbb{N}^m$ with

$$\sum_{i=1}^n \varepsilon_i = \sum_{j=1}^m s_j.$$

We denote by $\mathbf{F}(\mathcal{M}, \mathbf{e}, \mathbf{s})$ the set of fillings M of \mathcal{M} such that the row R_i has exactly ε_i many 1's, and the column C_j has exactly s_j many 1's, for $1 \leq i \leq n$ and $1 \leq j \leq m$. See Figure 1 for an illustration.

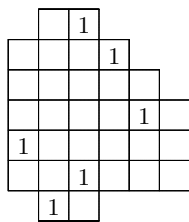

Figure 1: A filling M with $\mathbf{e} = (1, 1, 0, 1, 1, 1, 1)$ and $\mathbf{s} = (1, 1, 2, 1, 1, 0)$.

A *northeast* (resp. *southeast*) *chain* in a filling M of \mathcal{M} is a set of two 1-cells such that one of them is strictly above (resp. below) and to the right of the other and the smallest rectangle containing them is contained in \mathcal{M} . Northeast (resp. southeast) chains will be called NE (resp. SE) chains. The number of NE (resp. SE) chains of M is denoted by $\text{ne}(M)$ (resp. $\text{se}(M)$).

Let \mathcal{R} be the set of rows of the moon polyomino \mathcal{M} . For $S \subseteq [n]$, let

$$\mathcal{R}(S) = \bigcup_{i \in S} R_i.$$

We say a 1-cell is an *S-cell* if it lies in $\mathcal{R}(S)$. An NE chain is called a *top S-NE chain* if its northeast 1-cell is an *S-cell*. Similarly, an SE chain is called a *top S-SE chain* if its northwest 1-cell is an *S-cell*. In other words, an NE/SE chain is a *top S-NE/SE chain* if the upper 1-cell of the chain is in $\mathcal{R}(S)$. Similarly, an NE/SE chain is a *bottom S-NE/SE chain* if the lower 1-cell of the chain is in $\mathcal{R}(S)$.

Let $\bar{S} = [n] \setminus S$ be the complement of S . Given a filling $M \in \mathbf{F}(\mathcal{M}, \mathbf{e}, \mathbf{s})$, we define the *top-mixed statistic* $\alpha(S; M)$ and the *bottom-mixed statistic* $\beta(S; M)$ with respect to S as

$$\begin{aligned} \alpha(S; M) &= \#\{\text{top } S\text{-NE chain of } M\} + \#\{\text{top } \bar{S}\text{-SE chain of } M\}, \\ \beta(S; M) &= \#\{\text{bottom } S\text{-NE chain of } M\} + \#\{\text{bottom } \bar{S}\text{-SE chain of } M\}. \end{aligned}$$

See Example 2.2 for some of these statistics on the filling M in Figure 1.

Let $F_S^t(p, q)$ and $F_S^b(p, q)$ be the bi-variate generating functions for the pairs $(\alpha(S; M), \alpha(\bar{S}; M))$ and $(\beta(S; M), \beta(\bar{S}; M))$ respectively, namely,

$$F_S^t(p, q) = \sum_{M \in \mathbf{F}(\mathcal{M}, \mathbf{e}, \mathbf{s})} p^{\alpha(S; M)} q^{\alpha(\bar{S}; M)} \quad \text{and} \quad F_S^b(p, q) = \sum_{M \in \mathbf{F}(\mathcal{M}, \mathbf{e}, \mathbf{s})} p^{\beta(S; M)} q^{\beta(\bar{S}; M)}.$$

Note that

$$(\alpha(\emptyset; M), \alpha([n]; M)) = (\beta(\emptyset; M), \beta([n]; M)) = (\text{se}(M), \text{ne}(M)).$$

Our first result is the following property.

Theorem 2.1. $F_S^t(p, q) = F_{S'}^t(p, q)$ for any two subsets S, S' of $[n]$. In other words, the bi-variate generating function $F_S^t(p, q)$ does not depend on S . Consequently,

$$F_S^t(p, q) = F_\emptyset^t(p, q) = \sum_{M \in \mathbf{F}(\mathcal{M}, \mathbf{e}, \mathbf{s})} p^{\text{se}(M)} q^{\text{ne}(M)}$$

is a symmetric function. The same statement holds for $F_S^b(p, q)$.

We can also define the mixed statistics with respect to a subset of columns. Let \mathcal{C} be the set of columns of \mathcal{M} . For $T \subseteq [m]$, let

$$\mathcal{C}(T) = \bigcup_{j \in T} C_j.$$

An NE chain is called a *left T -NE chain* if the southwest 1-cell of the chain lies in $\mathcal{C}(T)$. Similarly, an SE chain is called a *left T -SE chain* if the northwest 1-cell of the chain lies in $\mathcal{C}(T)$. In other words, an NE/SE chain is a left T -NE/SE chain if its left 1-cell is in $\mathcal{C}(T)$. Similarly, an NE/SE chain is a *right T -NE/SE chain* if its right 1-cell is in $\mathcal{C}(T)$.

Let $\bar{T} = [m] \setminus T$ be the complement of T . For any filling M of $\mathbf{F}(\mathcal{M}, \mathbf{e}, \mathbf{s})$, we define the *left-mixed statistic* $\gamma(T; M)$ and the *right-mixed statistic* $\delta(T; M)$ with respect to T as

$$\begin{aligned} \gamma(T; M) &= \#\{\text{left } T\text{-NE chain of } M\} + \#\{\text{left } \bar{T}\text{-SE chain of } M\}, \\ \delta(T; M) &= \#\{\text{right } T\text{-NE chain of } M\} + \#\{\text{right } \bar{T}\text{-SE chain of } M\}. \end{aligned}$$

Example 2.2. Let M be the filling in Figure 1, where $\text{ne}(M) = 6$ and $\text{se}(M) = 1$. Let $S = \{2, 4\}$, i.e., $\mathcal{R}(S)$ contains the second and the fourth rows. Then

$$\alpha(S; M) = 5, \quad \alpha(\bar{S}; M) = 2, \quad \beta(S; M) = 1, \quad \beta(\bar{S}; M) = 6.$$

Let $T = \{1, 3\}$, i.e., $\mathcal{C}(T)$ contains the first and the third columns. Then

$$\gamma(T; M) = 4, \quad \gamma(\bar{T}; M) = 3, \quad \delta(T; M) = 2, \quad \delta(\bar{T}; M) = 5. \quad \blacksquare$$

Let $G_T^l(p, q)$ and $G_T^r(p, q)$ be the bi-variate generating functions of the pairs $(\gamma(T; M), \gamma(\bar{T}; M))$ and $(\delta(T; M), \delta(\bar{T}; M))$ respectively, namely,

$$G_T^l(p, q) = \sum_{M \in \mathbf{F}(\mathcal{M}, \mathbf{e}, \mathbf{s})} p^{\gamma(T; M)} q^{\gamma(\bar{T}; M)} \quad \text{and} \quad G_T^r(p, q) = \sum_{M \in \mathbf{F}(\mathcal{M}, \mathbf{e}, \mathbf{s})} p^{\delta(T; M)} q^{\delta(\bar{T}; M)}.$$

Again note that

$$(\gamma(\emptyset; M), \gamma([m]; M)) = (\delta(\emptyset; M), \delta([m]; M)) = (\text{se}(M), \text{ne}(M)).$$

Our second result shows that the generating function $G_T^l(p, q)$ possesses a similar property as $F_S^t(p, q)$.

Theorem 2.3. $G_T^l(p, q) = G_{T'}^l(p, q)$ for any two subsets T, T' of $[m]$. In other words, the bi-variate generating function $G_T^l(p, q)$ does not depend on T . Consequently,

$$G_T^l(p, q) = G_\emptyset^l(p, q) = \sum_{M \in \mathbf{F}(\mathcal{M}, \mathbf{e}, \mathbf{s})} p^{\text{se}(M)} q^{\text{ne}(M)}$$

is a symmetric function. The same statement holds for $G_T^r(p, q)$.

We notice that the set $\mathbf{F}(\mathcal{M}, \mathbf{e}, \mathbf{s})$ appeared as $\mathcal{N}^r(T, \mathbf{m}, A)$ in Kasraoui [10], where \mathbf{m} is the column sum vector, and A is the set of empty rows, i.e., $A = \{i : \varepsilon_i = 0\}$. Kasraoui also considered the set $\mathcal{N}^c(T, \mathbf{n}, B)$ of fillings whose row sum is an arbitrary \mathbb{N} -vector \mathbf{n} under the condition that there is at most one 1 in each column and where B is the set of empty columns. By a rotation of moon polyominoes, it is easily seen that Theorem 2.1 and Theorem 2.3 also hold for the set $\mathcal{N}^c(T, \mathbf{n}, B)$, as well as for the set of fillings such that there is at most one 1 in each row and in each column.

3 Mixed Statistics in Special Shapes

In this section we show how Theorems 2.1 and 2.3 specialize to classical combinatorial objects, including permutations, words, matchings, set partitions, and simple graphs.

We first consider the case of permutations and words. Fillings of an $n \times m$ rectangle \mathcal{M} are in bijection with words of length n on $[m]$. More precisely, a word $w = w_1 w_2 \cdots w_n$ on $[m]$ can be represented as a filling M in which the cell in row $n + 1 - i$ and column j is assigned the integer 1 if and only if $w_i = j$. In the word $w_1 w_2 \cdots w_n$, a pair (w_i, w_j) is an *inversion* if $i < j$ and $w_i > w_j$; we say that it is a *co-inversion* if $i < j$ and $w_i < w_j$, see also [14]. Denote by $\text{inv}(w)$ the number of inversions of w , and by $\text{coinv}(w)$ the number of co-inversions of w .

For $S \subseteq [n]$, the statistics $\alpha(S; M)$ and $\beta(S; M)$ become

$$\begin{aligned} \alpha(S; w) = & \#\{(w_i, w_j) : n + 1 - j \in S \text{ and } (w_i, w_j) \text{ is a co-inversion}\} \\ & + \#\{(w_i, w_j) : n + 1 - j \notin S \text{ and } (w_i, w_j) \text{ is an inversion}\}, \end{aligned}$$

and

$$\begin{aligned} \beta(S; w) = & \#\{(w_i, w_j) : n + 1 - i \in S \text{ and } (w_i, w_j) \text{ is a co-inversion}\} \\ & + \#\{(w_i, w_j) : n + 1 - i \notin S \text{ and } (w_i, w_j) \text{ is an inversion}\}. \end{aligned}$$

For $T \subseteq [m]$, the statistics $\gamma(T; M)$ and $\delta(T; M)$ become

$$\begin{aligned} \gamma(T, w) = & \#\{(w_i, w_j) : w_i \in T \text{ and } (w_i, w_j) \text{ is a co-inversion}\} \\ & + \#\{(w_i, w_j) : w_j \notin T \text{ and } (w_i, w_j) \text{ is an inversion}\}, \end{aligned}$$

and

$$\begin{aligned} \delta(T, w) = & \#\{(w_i, w_j) : w_j \in T \text{ and } (w_i, w_j) \text{ is a co-inversion}\} \\ & + \#\{(w_i, w_j) : w_i \notin T \text{ and } (w_i, w_j) \text{ is an inversion}\}. \end{aligned}$$

Let $W = \{1^{s_1}, 2^{s_2}, \dots, m^{s_m}\}$ be a multiset with $s_1 + \dots + s_m = n$. We adopt the notation $R(W)$ for the set of permutations, also called rearrangements, of the elements in W . Let $\lambda(A; w)$ denote any of the four statistics $\alpha(S; w), \beta(S; w), \gamma(T; w), \delta(T; w)$. Theorems 2.1 and 2.3 imply that the bi-variate generating function for $(\lambda(A; w), \lambda(\bar{A}; w))$ is symmetric and

$$\sum_{w \in R(W)} p^{\lambda(A; w)} q^{\lambda(\bar{A}; w)} = \sum_{w \in R(W)} p^{\text{inv}(w)} q^{\text{coinv}(w)} = \begin{bmatrix} n \\ s_1, \dots, s_m \end{bmatrix}_{p, q}, \quad (1)$$

where $\begin{bmatrix} n \\ s_1, \dots, s_m \end{bmatrix}_{p, q}$ is the p, q -Gaussian coefficient

$$\begin{bmatrix} n \\ s_1, \dots, s_m \end{bmatrix}_{p, q} = \frac{[n]_{p, q}!}{[s_1]_{p, q}! \cdots [s_m]_{p, q}!}.$$

As usual, the p, q -integer $[r]_{p, q}$ is given by

$$[r]_{p, q} = \frac{p^r - q^r}{p - q} = p^{r-1} + p^{r-2}q + \dots + pq^{r-2} + q^{r-1},$$

and the p, q -factorial $[r]_{p, q}!$ is defined as $[r]_{p, q}! = \prod_{i=1}^r [i]_{p, q}$.

We note that the symmetry of the distribution of $(\lambda(A; w), \lambda(\bar{A}; w))$ can be easily seen from the map $w_1 \cdots w_n \rightarrow (m+1-w_1) \cdots (m+1-w_n)$ for α and β , and the map $w_1 \cdots w_n \rightarrow w_n \cdots w_1$ for γ and δ . Nevertheless, the generating function Eq. (1) seems to be new. Chebikin [1] has considered the special case of $\alpha(S; w)$ when S is the set of even integers and w ranges over all permutations of $[n]$.

We now consider the case of matchings and set partitions. As can be seen in de Mier [7] and Chen et al. [5], general fillings of Ferrers diagrams correspond to multigraphs, which include matchings, set partitions, and linked set partitions. For simplicity, we give a description only for matchings. Given a matching π on $[2n]$, let $l_1 < l_2 < \dots < l_n$ be the left-hand endpoints, and $r_1 < r_2 < \dots < r_n$ be the right-hand endpoints. It determines a Ferrers diagram \mathcal{F} whose rows are indexed by l_1, \dots, l_n and columns are indexed by r_n, \dots, r_1 , where a cell (l_r, r_k) is in the Ferrers diagram if and only if l_r is on the left of r_k . The cell (l_r, r_k) is assigned the integer 1 if and only if (l_r, r_k) is an arc of the matching π . See Figure 2 for an example.

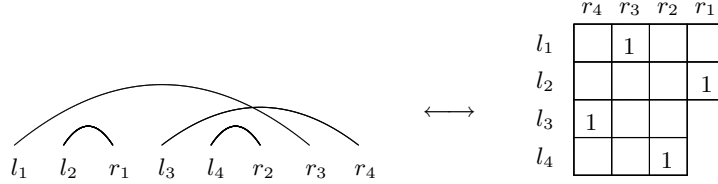

Figure 2: A matching and the corresponding filling of Ferrers diagram.

A subset of rows corresponds to a subset S of the left-hand endpoints $\{l_1, \dots, l_n\}$. The statistic $\alpha(S; M)$ corresponds to the mixed crossing-nesting statistic with respect to the first left-hand endpoint. More precisely, for a crossing formed by two edges (i_1, j_1) and (i_2, j_2) with $i_1 < i_2 < j_1 < j_2$, it is said to be an S -crossing if $i_1 \in S$. Similarly, a nesting formed by two edges (i_1, j_1) and (i_2, j_2) with $i_1 < i_2 < j_2 < j_1$ is said to be an S -nesting if $i_1 \in S$. Thus the statistic $\alpha(S; M)$ becomes

$$\alpha(S; \pi) = \#\{S\text{-crossing of } \pi\} + \#\{\bar{S}\text{-nesting of } \pi\}.$$

Theorem 2.1 asserts that $\sum_{\pi} p^{\alpha(S;\pi)} q^{\alpha(\bar{S};\pi)}$ is symmetric and independent of S , where π ranges over $P_n(A, B)$, the set of matchings with a given set of left-hand endpoints A and a given set of right-hand endpoints B . In particular, for each r_i , let

$$h_i = \#\{\text{cell in the column indexed by } r_i\} - (i - 1).$$

By the generating function for the numbers of crossings and nestings [3, 11], we have

$$\sum_{\pi \in P_n(A, B)} p^{\alpha(S;\pi)} q^{\alpha(\bar{S};\pi)} = \prod_{i=1}^n [h_i]_{p, q}, \quad (2)$$

for any $S \subseteq \{l_1, \dots, l_n\}$. It is worth noting some immediate consequences of Eq. (2). For example, for any non-empty set $P_n(A, B)$, there is exactly one matching π such that $\alpha(S; \pi) = 0$. It is not hard to construct such a matching. Hence the number of matchings on $[2n]$ with $\alpha(S; \pi) = 0$ is given by the n -th Catalan number. Similar statements hold when one considers the mixed crossing-nesting statistics with respect to the second left-hand endpoint, the first right-hand endpoint, and the second right-hand endpoint, respectively.

All the above results can be extended to set partitions [11] and linked set partitions [4], or more generally, to simple graphs for which the left-degree of every vertex is at most 1, or the right-degree of every vertex is at most 1, see de Mier [7]. Another way to see this is to associate a simple graph with a filling of the triangular Ferrers diagram $\Delta_n = (n - 1, n - 2, \dots, 1)$, see, for example, [13, 7].

4 Proof of the Main Results

It is sufficient to prove our results for $\alpha(S; M)$ and $\gamma(T; M)$ only, since conclusions for $\beta(S; M)$ and $\delta(T; M)$ can be obtained by reflecting the moon polyomino with respect to a horizontal line or a vertical line.

In Subsection 4.1, we recall Kasraoui's bijection Ψ from $\mathbf{F}(\mathcal{M}, \mathbf{e}, \mathbf{s})$ to sequences of compositions [10]. Kasraoui's construction is stated for the set $\mathcal{N}^c(T, \mathbf{n}, B)$. We shall give a description to fit our notation. The detailed justification of the bijection Ψ can be found in [10], and hence is omitted. This bijection will be used in the proof of Lemma 4.6 which states that the pair of the top-mixed statistics $(\alpha(\{1\}; M), \alpha(\overline{\{1\}}; M))$ is equidistributed with $(\text{se}(M), \text{ne}(M))$. Theorem 2.1 follows from an iteration of Lemma 4.6. In Subsection 4.3 we provide two proofs of Theorem 2.3. Again the crucial step is the observation that $(\gamma(\{1\}; M), \gamma(\overline{\{1\}}; M))$ has the same distribution as $(\text{se}(M), \text{ne}(M))$.

4.1 Kasraoui's bijection Ψ

If the columns of \mathcal{M} are C_1, \dots, C_m from left to right, it is clear that the sequence of their lengths is unimodal and there exists a unique k such that

$$|C_1| \leq \dots \leq |C_{k-1}| < |C_k| \geq |C_{k+1}| \geq \dots \geq |C_m|,$$

where $|C_i|$ is the length of the column C_i . The left part of \mathcal{M} , denoted $L(\mathcal{M})$, is the set of columns C_i 's with $1 \leq i \leq k - 1$, and the right part of \mathcal{M} , denoted $R(\mathcal{M})$, is the set of columns C_i 's with $k \leq i \leq m$. Note that the columns of maximal length in \mathcal{M} belong to $R(\mathcal{M})$.

We order the columns C_1, \dots, C_m by a total order \prec as follows: $C_i \prec C_j$ if and only if

- $|C_i| < |C_j|$ or
- $|C_i| = |C_j|$, $C_i \in L(\mathcal{M})$ and $C_j \in R(\mathcal{M})$, or
- $|C_i| = |C_j|$, $C_i, C_j \in L(\mathcal{M})$ and C_i is on the left of C_j , or
- $|C_i| = |C_j|$, $C_i, C_j \in R(\mathcal{M})$ and C_i is on the right of C_j .

For every column $C_i \in L(\mathcal{M})$, we define the rectangle $\mathcal{M}(C_i)$ to be the largest rectangle that contains C_i as the leftmost column. For $C_i \in R(\mathcal{M})$, the rectangle $\mathcal{M}(C_i)$ is taken to be the largest rectangle that contains C_i as the rightmost column and does not contain any column $C_j \in L(\mathcal{M})$ such that $C_j \prec C_i$.

Given $M \in \mathbf{F}(\mathcal{M}, \mathbf{e}, \mathbf{s})$, we define a coloring of M by the following steps.

The coloring of the filling M

1. Color the cells of empty rows;
2. For each $C_i \in L(\mathcal{M})$, color the cells which are contained in the rectangle $\mathcal{M}(C_i)$ and on the right of any 1-cell in C_i .
3. For each $C_i \in R(\mathcal{M})$, color the cells which are contained in the rectangle $\mathcal{M}(C_i)$ and on the left of any 1-cell in C_i .

Given M with the coloring, let ce be a cell of \mathcal{M} . If ce is a 1-cell, we denote by $\text{auc}(ce; M)$ (resp. $\text{buc}(ce; M)$) the number of uncolored empty cells in the same column as ce and above (resp. below) ce . If ce is empty, we set $\text{auc}(ce; M) = \text{buc}(ce; M) = 0$.

Proposition 4.1. *Let $M \in \mathbf{F}(\mathcal{M}, \mathbf{e}, \mathbf{s})$ and ce be a 1-cell of C_i .*

1. *If $C_i \in L(\mathcal{M})$, then $\text{auc}(ce; M)$ (resp. $\text{buc}(ce; M)$) is equal to the number of NE (resp. SE) chains contained in the rectangle $\mathcal{M}(C_i)$ whose southwest (resp. northwest) 1-cell is ce ;*
2. *If $C_i \in R(\mathcal{M})$, then $\text{auc}(ce; M)$ (resp. $\text{buc}(ce; M)$) is equal to the number of SE (resp. NE) chains contained in the rectangle $\mathcal{M}(C_i)$ whose southeast (resp. northeast) 1-cell is ce .*

Example 4.2. Let M be the 01-filling in Figure 1, where $L(\mathcal{M}) = \{C_1\}$ and $R(\mathcal{M}) = \{C_2, \dots, C_6\}$. Let ce be the 1-cell in the first column, and ce' the 1-cell in the fifth column. Then $\text{auc}(ce; M) = 1$, $\text{buc}(ce; M) = 1$, $\text{auc}(ce'; M) = 0$, and $\text{buc}(ce'; M) = 2$; See Figure 3.

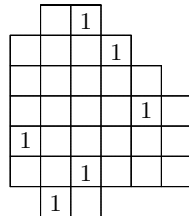

Figure 3: The statistics auc and buc for cells in a 01-filling.

The following theorem can be deduced from Prop. 4.1.

Theorem 4.3.

$$\begin{aligned} \text{ne}(M) &= \sum_{\text{ce} \in L(\mathcal{M})} \text{auc}(\text{ce}; M) + \sum_{\text{ce} \in R(\mathcal{M})} \text{buc}(\text{ce}; M), \\ \text{se}(M) &= \sum_{\text{ce} \in L(\mathcal{M})} \text{buc}(\text{ce}; M) + \sum_{\text{ce} \in R(\mathcal{M})} \text{auc}(\text{ce}; M). \end{aligned}$$

For $M \in \mathbf{F}(\mathcal{M}, \mathbf{e}, \mathbf{s})$, let a_i be the number of empty rows (i.e., $\{R_i : \varepsilon_i = 0\}$) that intersect the column C_i . Suppose that $C_{i_1} \prec C_{i_2} \prec \cdots \prec C_{i_m}$. For $j = 1, \dots, m$, we define

$$h_{i_j} = |C_{i_j}| - a_{i_j} - (s_{i_1} + s_{i_2} + \cdots + s_{i_{j-1}}). \quad (3)$$

Note that the numbers h_i 's have the following interpretation. If one puts 1-cells in the columns of M from the smallest to the largest under the order \prec , then h_{i_j} is the number of available cells in the j -th column to be filled. For positive integers n and k , denote by $\mathcal{C}_k(n)$ the set of compositions of n into k nonnegative parts, that is, $\mathcal{C}_k(n) = \{(\lambda_1, \lambda_2, \dots, \lambda_k) \in \mathbb{N}^k : \sum_{i=1}^k \lambda_i = n\}$. The bijection Ψ is constructed as follows.

The bijection $\Psi : \mathbf{F}(\mathcal{M}, \mathbf{e}, \mathbf{s}) \longrightarrow \mathcal{C}_{s_1+1}(h_1 - s_1) \times \mathcal{C}_{s_2+1}(h_2 - s_2) \times \cdots \times \mathcal{C}_{s_m+1}(h_m - s_m)$.

For each $M \in \mathbf{F}(\mathcal{M}, \mathbf{e}, \mathbf{s})$ with the coloring, $\Psi(M)$ is a sequence of compositions $(c^{(1)}, c^{(2)}, \dots, c^{(m)})$, where

- $c^{(i)} = (0)$ if $s_i = 0$. Otherwise
- $c^{(i)} = (c_1^{(i)}, c_2^{(i)}, \dots, c_{s_i+1}^{(i)})$ where
 - $c_1^{(i)}$ is the number of uncolored cells above the first 1-cell in the column C_i ;
 - $c_k^{(i)}$ is the number of uncolored cells between the $(k-1)$ -st and the k -th 1-cells in the column C_i , for $2 \leq k \leq s_i$;
 - $c_{s_i+1}^{(i)}$ is the number of uncolored cells below the last 1-cell in the column C_i .

Let $\mathbf{c} = \Psi(M) = (c^{(1)}, c^{(2)}, \dots, c^{(m)})$, and ce be the k -th 1-cell in the column C_i . It follows from the bijection Ψ that

$$\begin{aligned} \text{auc}(\text{ce}; M) &= c_1^{(i)} + c_2^{(i)} + \cdots + c_k^{(i)}, \\ \text{buc}(\text{ce}; M) &= c_{k+1}^{(i)} + c_{k+2}^{(i)} + \cdots + c_{s_i+1}^{(i)} = h_i - s_i - (c_1^{(i)} + c_2^{(i)} + \cdots + c_k^{(i)}). \end{aligned}$$

Now Theorem 4.3 can be rewritten as

Theorem 4.4. *Let $M \in \mathbf{F}(\mathcal{M}, \mathbf{e}, \mathbf{s})$ and $\mathbf{c} = \Psi(M) = (c^{(1)}, c^{(2)}, \dots, c^{(m)})$. Then*

$$\begin{aligned} \text{ne}(M) &= \sum_{C_i \in L(\mathcal{M})} \sum_{k=1}^{s_i} (c_1^{(i)} + c_2^{(i)} + \cdots + c_k^{(i)}) + \sum_{C_j \in R(\mathcal{M})} \sum_{k=1}^{s_j} (h_j - s_j - c_1^{(j)} - c_2^{(j)} - \cdots - c_k^{(j)}), \\ \text{se}(M) &= \sum_{C_i \in L(\mathcal{M})} \sum_{k=1}^{s_i} (h_i - s_i - c_1^{(i)} - c_2^{(i)} - \cdots - c_k^{(i)}) + \sum_{C_j \in R(\mathcal{M})} \sum_{k=1}^{s_j} (c_1^{(j)} + c_2^{(j)} + \cdots + c_k^{(j)}). \end{aligned}$$

Summing over the sequences of compositions yields the symmetric generating function.

Theorem 4.5 (Kasraoui).

$$\sum_{M \in \mathbf{F}(\mathcal{M}, \mathbf{e}, \mathbf{s})} p^{\text{ne}(M)} q^{\text{se}(M)} = \sum_{M \in \mathbf{F}(\mathcal{M}, \mathbf{e}, \mathbf{s})} p^{\text{se}(M)} q^{\text{ne}(M)} = \prod_{i=1}^m \left[\begin{matrix} h_i \\ s_i \end{matrix} \right]_{p,q}.$$

4.2 Proof of Theorem 2.1

To prove Theorem 2.1 for the top-mixed statistic $\alpha(S; M)$, we first consider the special case when $\mathcal{R}(S)$ contains the first row only.

Lemma 4.6. *For $S = \{1\}$, we have*

$$F_{\{1\}}^t(p, q) = F_{\emptyset}^t(p, q) = \sum_{M \in \mathbf{F}(\mathcal{M}, \mathbf{e}, \mathbf{s})} p^{\text{se}(M)} q^{\text{ne}(M)}.$$

Proof. We assume that the first row is nonempty. Otherwise the identity is obvious. Given a filling $M \in \mathbf{F}(\mathcal{M}, \mathbf{e}, \mathbf{s})$, assume that the unique 1-cell of the first row lies in the column C_t . Let the upper polyomino \mathcal{M}_u be the union of the rows that intersect C_t , and the lower polyomino \mathcal{M}_d be the complement of \mathcal{M}_u , i.e., $\mathcal{M}_d = \mathcal{M} \setminus \mathcal{M}_u$. We aim to construct a bijection $\phi_\alpha : \mathbf{F}(\mathcal{M}, \mathbf{e}, \mathbf{s}) \rightarrow \mathbf{F}(\mathcal{M}, \mathbf{e}, \mathbf{s})$ such that for any filling M ,

$$(\alpha(\{1\}; M), \alpha(\overline{\{1\}}; M)) = (\text{se}(\phi_\alpha(M)), \text{ne}(\phi_\alpha(M))),$$

and $\phi_\alpha(M)$ is identical to M on \mathcal{M}_d .

Let $M_u = M \cap \mathcal{M}_u$ and $M_d = M \cap \mathcal{M}_d$. Let s'_i be the number of 1-cells of M in the column $C_i \cap \mathcal{M}_u$, and $\mathbf{s}' = (s'_1, \dots, s'_m)$. Let $\mathbf{e}' = (\varepsilon_1, \dots, \varepsilon_r)$, where r is the number of rows in \mathcal{M}_u . We shall define ϕ_α on $\mathbf{F}(\mathcal{M}_u, \mathbf{e}', \mathbf{s}')$ such that $\phi_\alpha(M_u) \in \mathbf{F}(\mathcal{M}_u, \mathbf{e}', \mathbf{s}')$ and

$$(\alpha(\{1\}; M_u), \alpha(\overline{\{1\}}; M_u)) = (\text{se}(\phi_\alpha(M_u)), \text{ne}(\phi_\alpha(M_u))).$$

Let $C'_i = C_i \cap \mathcal{M}_u$. Suppose that in \mathcal{M} the columns intersecting with the first row are $C_a, \dots, C_t, \dots, C_b$ from left to right. Then $C_t = C'_t$, and in \mathcal{M}_u the columns $C'_a, \dots, C'_t, \dots, C'_b$ intersect the first row. Assume that among them the ones with the same length as C'_t are $C'_u, \dots, C'_t, \dots, C'_v$ from left to right. Clearly, the columns $C'_u, \dots, C'_t, \dots, C'_v$ are those with maximal length and belong to $R(\mathcal{M}_u)$. Note that in M_u , the number of top $\{1\}$ -NE chains is $\sum_{a \leq i < t} s'_i$, while the number of top $\{1\}$ -SE chains is $\sum_{t < i \leq b} s'_i$. Let h'_i be given as in Eq. (3) for $\mathbf{F}(\mathcal{M}_u, \mathbf{e}', \mathbf{s}')$. Let $\mathbf{c} = \Psi(M_u) = (c^{(1)}, c^{(2)}, \dots, c^{(m)})$, from Theorem 4.4 we see that

$$\begin{aligned} \alpha(\{1\}; M_u) &= \sum_{a \leq i < t} s'_i + \sum_{C'_i \in L(\mathcal{M}_u)} \sum_{k=1}^{s'_i} (h'_i - s'_i - c_1^{(i)} - c_2^{(i)} - \dots - c_k^{(i)}) \\ &\quad + \sum_{C'_j \in R(\mathcal{M}_u)} \sum_{k=1}^{s'_j} (c_1^{(j)} + c_2^{(j)} + \dots + c_k^{(j)}) - \sum_{t < i \leq b} s'_i \\ &= \sum_{a \leq i < u} s'_i + (h'_t - s'_t) + \sum_{C'_i \in L(\mathcal{M}_u)} \sum_{k=1}^{s'_i} (h'_i - s'_i - c_1^{(i)} - c_2^{(i)} - \dots - c_k^{(i)}) \end{aligned}$$

$$+ \sum_{C'_j \in R(\mathcal{M}_u)} \sum_{k=1}^{s'_j} (c_1^{(j)} + c_2^{(j)} + \cdots + c_k^{(j)}) - \sum_{t < i \leq b} s'_i. \quad (4)$$

The second equation holds since $C'_t \prec C'_{t-1} \prec \cdots \prec C'_u$ are the largest $t - u + 1$ columns in $R(\mathcal{M}_u)$ under the order \prec . By definition h'_t is the number of available rows when all the smaller columns of \mathcal{M}_u have been filled. Those available rows will be filled by the 1's in the columns C'_t, \dots, C'_u . Hence $h'_t = s'_t + \cdots + s'_u$. Similarly, we have

$$\begin{aligned} \alpha(\overline{\{1\}}; M_u) &= \sum_{t < i \leq b} s'_i + \sum_{C'_i \in L(\mathcal{M}_u)} \sum_{k=1}^{s'_i} (c_1^{(i)} + c_2^{(i)} + \cdots + c_k^{(i)}) \\ &+ \sum_{C'_j \in R(\mathcal{M}_u)} \sum_{k=1}^{s'_j} (h'_j - s'_j - c_1^{(j)} - c_2^{(j)} - \cdots - c_k^{(j)}) - \sum_{a \leq i < t} s'_i \\ &= \sum_{t < i \leq b} s'_i + \sum_{C'_i \in L(\mathcal{M}_u)} \sum_{k=1}^{s'_i} (c_1^{(i)} + c_2^{(i)} + \cdots + c_k^{(i)}) \\ &+ \sum_{C'_j \in R(\mathcal{M}_u)} \sum_{k=1}^{s'_j} (h'_j - s'_j - c_1^{(j)} - c_2^{(j)} - \cdots - c_k^{(j)}) - \sum_{a \leq i < u} s'_i. \quad (5) \end{aligned}$$

The fact that the 1-cell of the first row lies in the column C'_t implies that $c_1^{(t)} = 0$, and $c_1^{(i)} > 0$ for $a \leq i < u$ or $t < i \leq b$. We define the filling $\phi_\alpha(M_u)$ by setting $\phi_\alpha(M_u) = \Psi^{-1}(\tilde{\mathbf{c}})$, where $\tilde{\mathbf{c}}$ is obtained from \mathbf{c} as follows:

$$\begin{cases} \tilde{c}^{(i)} = (c_1^{(i)} - 1, c_2^{(i)}, \dots, c_{s_i}^{(i)}, c_{s_i+1}^{(i)} + 1), & \text{if } a \leq i < u \text{ or } t < i \leq b, \text{ and } s'_i \neq 0, \\ \tilde{c}^{(t)} = (c_2^{(t)}, c_3^{(t)}, \dots, c_{s_t+1}^{(t)}, c_1^{(t)}), & \text{if } i = t, \\ \tilde{c}^{(i)} = c^{(i)}, & \text{for any other } i. \end{cases}$$

Comparing the formulas (4) and (5) with Theorem 4.4 for $\tilde{\mathbf{c}}$, it is easily verified that

$$(\alpha(\{1\}; M_u), \alpha(\overline{\{1\}}; M_u)) = (\text{se}(\phi_\alpha(M_u)), \text{ne}(\phi_\alpha(M_u))).$$

Now $\phi_\alpha(M)$ is obtained from M by replacing M_u with $\phi_\alpha(M_u)$.

Claim: $(\alpha(\{1\}; M), \alpha(\overline{\{1\}}; M)) = (\text{se}(\phi_\alpha(M)), \text{ne}(\phi_\alpha(M)))$ for any $M \in \mathbf{F}(\mathcal{M}, \mathbf{e}, \mathbf{s})$.

This is true because (1) M has the same number of top $\{1\}$ -NE/SE chains as M_u , since every top $\{1\}$ -NE/SE chains of M must appear in M_u ; (2) M_d appears in both M and $\phi_\alpha(M)$; (3) If (ce, ce') is an NE chain or an SE chain with $ce \in \mathcal{M}_u$ and $ce' \in \mathcal{M}_d$, by the intersection-free property of \mathcal{M} , both ce and ce' are in columns $\{C_a, \dots, C_b\}$. For any fixed $ce' \in \mathcal{M}_d$, the number of NE (resp. SE) chains formed by ce' and 1-cells ce in the column $C_j \cap \mathcal{M}_u$ is unchanged under the map ϕ_α since ϕ_α preserves the column sum and row sum of M_u .

To show that ϕ is a bijection on $\mathbf{F}(\mathcal{M}, \mathbf{e}, \mathbf{s})$, it is enough to explain how to determine from $\phi_\alpha(M)$ the column C_t , and hence the upper polyomino \mathcal{M}_u . Then the correspondence between \mathbf{c} and $\tilde{\mathbf{c}}$ becomes obvious. To this end, we shall use the map Ψ defined in Subsection 4.1. If the columns intersecting the first row are C_a, \dots, C_b in \mathcal{M} , then C_t is the smallest column in $\{C_a, \dots, C_b\}$ under the order \prec with the property that the last entry $c_{s_t+1}^{(t)}$ is 0 in the corresponding composition $c^{(t)}$. The rest of the proof is straightforward. \blacksquare

Proposition 4.7. Assume $S = \{r_1, r_2, \dots, r_s\} \subseteq [n]$ with $r_1 < r_2 < \dots < r_s$. Let $S' = \{r_1, r_2, \dots, r_{s-1}\}$. Then $F_S^t(p, q) = F_{S'}^t(p, q)$.

Proof. Let $X = \{R_i : 1 \leq i < r_s\}$ be the set of rows above the row R_{r_s} , and Y be the set of remaining rows. Given a filling $M \in \mathbf{F}(\mathcal{M}, \mathbf{e}, \mathbf{s})$, let $\mathcal{T}(M)$ be the set of fillings $M' \in \mathbf{F}(\mathcal{M}, \mathbf{e}, \mathbf{s})$ that are identical to M in the rows of X . Construct a bijection $\theta_{r_s} : \mathcal{T}(M) \rightarrow \mathcal{T}(M)$ by setting $\theta_{r_s}(M)$ to be the filling obtained from M by replacing $M \cap Y$ with $\phi_\alpha(M \cap Y)$.

We proceed to show that

$$(\alpha(S; M), \alpha(\bar{S}; M)) = (\alpha(S'; \theta_{r_s}(M)), \alpha(\bar{S}'; \theta_{r_s}(M))). \quad (6)$$

There are three cases.

Case 1 An NE or an SE chain consisting of two 1-cells in X contributes equally to both pairs of statistics.

Case 2 By Lemma 4.6, the set of NE chains and SE chains consisting of two cells in Y contributes equally to both pairs of statistics.

Case 3 For a 1-cell ce in X , assume ce is in row R_u and column C_t . Let $T = \{C_a, \dots, C_b\}$ be the set of columns intersecting both the rows R_{r_s} and R_u , and R_p ($p \geq r_s$) be the lowest row that intersects C_t . If ce forms an NE chain with a cell ce' in Y , then ce' is in a row on or above R_p , and in a column in $\{C_a, \dots, C_{t-1}\}$.

It follows that the number of NE chains of the form (ce, ce') for a fixed 1-cell $ce \in X$ equals the number of 1-cells in the area $\{(R_i, C_j) : r_s \leq i \leq p, a \leq j < t\}$, see Figure 4. This number is unchanged under the map ϕ_α , as ϕ_α preserves the column sum and the row sum, and hence the number of 1's in columns C_a, \dots, C_{t-1} , and the number of 1's in rows $\{R_i : i > p\}$. Similarly, the number of SE chains (ce, ce') with $ce \in X$ and $ce' \in Y$ is unchanged under the map ϕ_α . Thus NE and SE chains formed by one X -cell and one Y -cell contribute equally to the two pairs of statistics as well.

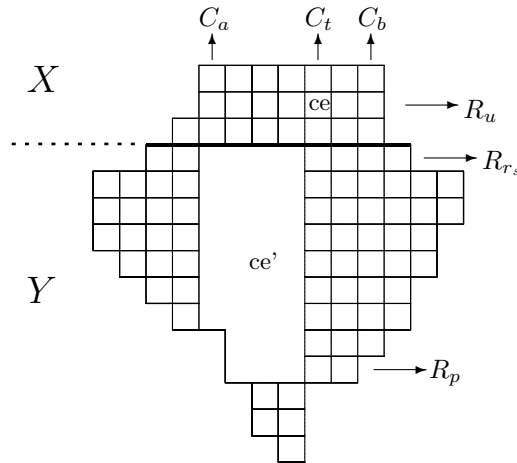

Figure 4: NE chains formed by the cell $ce \in X$ and Y -cells.

Thus (6) is proved by combining the above three cases. ■

Proof of Theorem 2.1. Assume $S = \{r_1, r_2, \dots, r_s\} \subseteq \mathcal{R}$ with $r_1 < r_2 < \dots < r_s$. Let $\Theta_\alpha = \theta_{r_1} \circ \theta_{r_2} \circ \dots \circ \theta_{r_s}$, where θ_r is defined in the proof of Prop. 4.7. Then Θ_α is a bijection on $\mathbf{F}(\mathcal{M}, \mathbf{e}, \mathbf{s})$ with the property that

$$(\alpha(S; M), \alpha(\bar{S}; M)) = (\text{se}(\Theta_\alpha(M)), \text{ne}(\Theta_\alpha(M))).$$

The symmetry of $F_S^l(p, q)$ follows from Theorem 4.5. ■

4.3 Proof of Theorem 2.3

Theorem 2.3 is concerned with the left-mixed statistic $\gamma(T; M)$. The proof is similar to that of Theorem 2.1. The key idea amounts to the observation that $(\gamma(\{1\}; M), \gamma(\overline{\{1\}}; M))$ is equidistributed with $(\text{se}(M), \text{ne}(M))$. We provide two proofs of this fact: one is based on generating functions, and the other is bijective.

Lemma 4.8. *For $T = \{1\}$, we have*

$$G_{\{1\}}^l(p, q) = G_\emptyset^l(p, q) = \prod_{i=1}^m \left[\begin{matrix} h_i \\ s_i \end{matrix} \right]_{p,q}.$$

First proof of Lemma 4.8. We conduct induction on the number of columns of \mathcal{M} . The statement is trivial if \mathcal{M} has only one column.

Assume that Lemma 4.8 holds for 01-fillings on any moon polyominoes with less than m columns. Suppose that \mathcal{M} have m columns. Consider the minimal column C under the order \prec . There are two cases.

1. $C = C_1$ is the leftmost column of \mathcal{M} . In this case we employ the bijection Ψ . For any filling M with $\Psi(M) = (c^{(1)}, c^{(2)}, \dots, c^{(m)})$, let $\tau(M) = \Psi^{-1}(c^{(1),r}, c^{(2)}, \dots, c^{(m)})$, where

$$c^{(1),r} = (c_{s_1+1}^{(1)}, \dots, c_2^{(1)}, c_1^{(1)}) \text{ if } c^{(1)} = (c_1^{(1)}, c_2^{(1)}, \dots, c_{s_1+1}^{(1)}).$$

It is readily checked that $(\gamma(\{1\}; M), \gamma(\overline{\{1\}}; M)) = (\text{se}(\tau(M)), \text{ne}(\tau(M)))$.

2. $C = C_m$ is the rightmost column of \mathcal{M} . We first prove the case for rectangular shapes. Assume \mathcal{M} is a rectangle with n non-empty rows. A filling M of \mathcal{M} can be read as a word $w = w_1 w_2 \dots w_n$ where $w_i = j$ if the only 1-cell in the $(n+1-i)$ -th non-empty row appears in the j -th column. It is clear that $\text{se}(M) = \text{inv}(w_1 w_2 \dots w_n)$ and $\text{ne}(M) = \text{coinv}(w_1 w_2 \dots w_n)$. In addition, fillings with a given column sum $\mathbf{s} = (s_1, \dots, s_m)$ correspond to words on the multiset $\{1^{s_1}, \dots, m^{s_m}\}$. Therefore

$$\sum_{M \in \mathbf{F}(\mathcal{M}, \mathbf{e}, \mathbf{s})} p^{\text{se}(M)} q^{\text{ne}(M)} = \left[\begin{matrix} n \\ s_1, \dots, s_m \end{matrix} \right]_{p,q}. \quad (7)$$

Observe that

$$\gamma(\{1\}; M) = \# \{(w_i, w_j) \mid w_i = 1 < w_j \text{ and } i < j\} + \# \{(w_i, w_j) \mid i < j \text{ and } w_i > w_j \neq 1\}.$$

Let $\epsilon(w_1 w_2 \cdots w_n) = \epsilon(w_1) \epsilon(w_2) \cdots \epsilon(w_n)$ where

$$\epsilon(w_i) = \begin{cases} m+1, & \text{if } w_i = 1, \\ w_i, & \text{otherwise.} \end{cases}$$

Then $\gamma(\{1\}; M) = \text{inv}(\epsilon(w_1 w_2 \cdots w_n))$. Similarly, $\gamma(\overline{\{1\}}; M) = \text{coinv}(\epsilon(w_1 w_2 \cdots w_n))$. When M ranges over $\mathbf{F}(\mathcal{M}, \mathbf{e}, \mathbf{s})$, the word $\epsilon(w_1 w_2 \cdots w_n)$ ranges over all rearrangements of the multiset $W = \{(m+1)^{s_1}, 2^{s_2}, \dots, m^{s_m}\}$. Hence

$$\sum_{M \in \mathbf{F}(\mathcal{M}, \mathbf{e}, \mathbf{s})} p^{\gamma(\{1\}; M)} q^{\gamma(\overline{\{1\}}; M)} = \sum_{w \in R(W)} p^{\text{inv}(w)} q^{\text{coinv}(w)} = \left[\begin{matrix} n \\ s_1, \dots, s_m \end{matrix} \right]_{p,q}. \quad (8)$$

Comparing (7) and (8), we complete the proof for a rectangular shape \mathcal{M} .

Now we deal with the case for a general shape \mathcal{M} . Let $\mathcal{M}(C)$ be the largest rectangle that contains C . Let $\mathcal{M}_1 = \mathcal{M} \setminus C$ and $\mathcal{M}_1(C) = \mathcal{M}(C) \setminus C$. By the inductive hypothesis, $(\gamma(\{1\}; M), \gamma(\overline{\{1\}}; M))$ has the same distribution as $(\text{se}(M), \text{ne}(M))$ over the set of fillings in $\mathbf{F}(\mathcal{M}_1, \mathbf{e}', \mathbf{s} - \{s_m\})$, where \mathbf{e}' is the row-vector when one removes the rows with a 1-cell in the column C . We analyze the contribution when one adds the last column C with s_m many 1-cells.

Given a filling M on \mathcal{M}_1 , let $\mathcal{S}(M)$ be the set of all fillings that have the same 1-cells in rows other than those in $\mathcal{M}_1(C)$. For any $N \in \mathcal{S}(M)$, let $N(C)$ be the restriction of N on $\mathcal{M}_1(C)$, then the values

$$\gamma(\{1\}; N) - \gamma(\{1\}; N(C)) \quad \text{and} \quad \gamma(\overline{\{1\}}; N) - \gamma(\overline{\{1\}}; N(C))$$

are constants over $\mathcal{S}(M)$, which will not change when the last column C is added. Note that $\mathcal{M}_1(C)$ is a rectangular shape. Hence $N(C)$ can be identified as a word of length n on $\{1^{s'_1}, 2^{s'_2}, \dots, (m-1)^{s'_{m-1}}\}$, where n is the number of non-empty rows in $\mathcal{M}_1(C)$, and s'_i is the number of 1's of M in $C_i \cap \mathcal{M}(C)$. By the argument for a rectangular shape, we find that

$$\sum_{N \in \mathcal{S}(M)} p^{\gamma(\{1\}; N(C))} q^{\gamma(\overline{\{1\}}; N(C))} = \left[\begin{matrix} n \\ s'_1, \dots, s'_{m-1} \end{matrix} \right]_{p,q}.$$

Adding the last column C with s_m 1-cells is equivalent to inserting s_m many m 's to a word on $\{1^{s'_1}, 2^{s'_2}, \dots, (m-1)^{s'_{m-1}}\}$. Again using the transformation $\epsilon(w_1 w_2 \cdots w_{n+s_m}) = \epsilon(w_1) \epsilon(w_2) \cdots \epsilon(w_{n+s_m})$, and assuming $W' = \{(m+1)^{s'_1}, 2^{s'_2}, \dots, (m-1)^{s'_{m-1}}, m^{s_m}\}$, we have

$$\begin{aligned} \sum_{M \in \mathbf{F}(\mathcal{M}(C), \mathbf{e}_1, \mathbf{s}' \cup \{s_m\})} p^{\gamma(\{1\}; M)} q^{\gamma(\overline{\{1\}}; M)} &= \sum_{w \in R(W')} p^{\text{inv}(w)} q^{\text{coinv}(w)} \\ &= \left[\begin{matrix} n + s_m \\ s'_1, \dots, s'_{m-1}, s_m \end{matrix} \right]_{p,q}, \end{aligned}$$

where \mathbf{e}_1 is the restriction of \mathbf{e} on the rows in $\mathcal{M}(C)$. Thus we deduce that the contribution of the last column C over the set $\mathcal{S}(M)$ is given by

$$\left[\begin{matrix} n + s_m \\ s'_1, \dots, s'_{m-1}, s_m \end{matrix} \right]_{p,q} / \left[\begin{matrix} n \\ s'_1, \dots, s'_{m-1} \end{matrix} \right]_{p,q} = \left[\begin{matrix} n + s_m \\ s_m \end{matrix} \right]_{p,q},$$

which is independent of s'_1, \dots, s'_{m-1} .

Summing over all distinct sets of the form $\mathcal{S}(M)$, we conclude that adding the last column C contributes a factor of $\begin{bmatrix} n+s_m \\ s_m \end{bmatrix}_{p,q}$ to $G_{\{1\}}^l(p, q)$. It follows from (3) that $n + s_m = h_m$. Hence an inductive argument yields

$$G_{\{1\}}^l(p, q) = \prod_{i=1}^m \begin{bmatrix} h_i \\ s_i \end{bmatrix}_{p,q} = G_{\emptyset}^l(p, q). \quad \blacksquare$$

The second proof of Lemma 4.8 is a bijection, which is built on an involution ρ on the fillings of a rectangular shape \mathcal{M} .

An involution ρ on rectangular shapes.

Let \mathcal{M} be an $n \times m$ rectangle. We order the columns of \mathcal{M} from left to right, i.e., $C_1 \prec' \dots \prec' C_m$, and set $L(\mathcal{M}) = \mathcal{M}$. For any filling M , give it the coloring as described in Subsection 4.1, and apply the bijection Ψ from $\mathbf{F}(\mathcal{M}, \mathbf{e}, \mathbf{s})$ to $\mathcal{C}_{s_1+1}(h_1 - s_1) \times \dots \times \mathcal{C}_{s_m+1}(h_m - s_m)$. For any filling M with $\Psi(M) = (c^{(1)}, c^{(2)}, \dots, c^{(m)})$ under the order \prec' , let $\rho(M)$ be the filling whose associated sequence of compositions is $(c^{(1),r}, c^{(2)}, \dots, c^{(m)})$, again under the order \prec' , where

$$c^{(1),r} = (c_{s_1+1}^{(1)}, \dots, c_2^{(1)}, c_1^{(1)}) \text{ if } c^{(1)} = (c_1^{(1)}, c_2^{(1)}, \dots, c_{s_1+1}^{(1)}).$$

Then it is easy to verify that $\rho(\rho(M)) = M$ and $(\gamma(\{1\}; M), \gamma(\overline{\{1\}}; M)) = (\text{se}(\rho(M)), \text{ne}(\rho(M)))$.

Second proof of Lemma 4.8. Given a general moon polyomino \mathcal{M} , assume that the rows intersecting the first column are $\{R_a, \dots, R_b\}$. Let \mathcal{M}_c be the union $R_a \cup \dots \cup R_b$. Clearly, for any $M \in \mathbf{F}(\mathcal{M}, \mathbf{e}, \mathbf{s})$, a left $\{1\}$ -NE (SE) chain consists of two 1-cells in \mathcal{M}_c . Let $C'_i = C_i \cap \mathcal{M}_c$ be the restriction of the column C_i on \mathcal{M}_c . Then $C'_1 = C_1$ and $|C'_1| \geq |C'_2| \geq \dots \geq |C'_m|$.

Suppose that

$$\begin{aligned} |C'_1| = |C'_2| = \dots = |C'_{j_1}| > |C'_{j_1+1}| = |C'_{j_1+2}| = \dots = |C'_{j_2}| > |C'_{j_2+1}| \dots \\ \dots = |C'_{j_{k-1}}| > |C'_{j_{k-1}+1}| = |C'_{j_{k-1}+2}| = \dots = |C'_{j_k}| = |C'_m|. \end{aligned}$$

Let B_i be the greatest rectangle contained in \mathcal{M}_c whose right most column is C'_{j_i} ($1 \leq i \leq k$), and $B'_i = B_i \cap B_{i+1}$ ($1 \leq i \leq k-1$).

We define $\phi_\gamma: \mathbf{F}(\mathcal{M}, \mathbf{e}, \mathbf{s}) \rightarrow \mathbf{F}(\mathcal{M}, \mathbf{e}, \mathbf{s})$ by constructing a sequence of fillings (M, M_k, \dots, M_1) starting from M .

The map $\phi_\gamma: \mathbf{F}(\mathcal{M}, \mathbf{e}, \mathbf{s}) \rightarrow \mathbf{F}(\mathcal{M}, \mathbf{e}, \mathbf{s})$

Let $M \in \mathbf{F}(\mathcal{M}, \mathbf{e}, \mathbf{s})$.

1. The filling M_k is obtained from M by replacing $M \cap B_k$ with $\rho(M \cap B_k)$.
2. For i from $k-1$ to 1:
 - (a) Define a filling N_i on B'_i by setting $N_i = \rho(M_{i+1} \cap B'_i)$. Let the filling M'_i be obtained from M_{i+1} by replacing $M_{i+1} \cap B'_i$ with N_i .
 - (b) The filling M_i is obtained from M'_i by replacing $M'_i \cap B_i$ with $\rho(M'_i \cap B_i)$.
3. Set $\phi_\gamma(M) = M_1$.

See Example 4.9 for an illustration.

Claim: $(\gamma(\{1\}; M), \gamma(\overline{\{1\}}; M)) = (\text{se}(\phi_\gamma(M)), \text{ne}(\phi_\gamma(M)))$.

We are able to keep track of the statistic $\gamma(\{1\}; M)$ in the above algorithm. In Step 1, by the definition of ρ we have

$$\begin{aligned} \gamma(\{1\}; M) &= \#\{\text{left } \{1\}\text{-NE chain of } M\} + \#\{\text{left } \overline{\{1\}}\text{-SE chain of } M\} \\ &= \#\{\text{left } \{1\}\text{-NE chain of } M_k\} + \#\{\text{left } \overline{\{1\}}\text{-SE chain of } M_k\} \\ &\quad - \#\{\text{left } \{1\}\text{-NE chain of } M_k \text{ in } B_k\} + \#\{\text{left } \{1\}\text{-SE chain of } M_k \text{ in } B_k\}. \end{aligned}$$

Let $\mathcal{B}_i = B_i \cup \dots \cup B_k$. For i from $k-1$ to 1, Step 2(a) implies that for the filling M'_i ,

$$\begin{aligned} \gamma(\{1\}; M) &= \#\{\text{left } \{1\}\text{-NE chain of } M'_i\} + \#\{\text{left } \overline{\{1\}}\text{-SE chain of } M'_i\} \\ &\quad - \#\{\text{left } \{1\}\text{-NE chain of } M'_i \text{ in } \mathcal{B}_{i+1}\} + \#\{\text{left } \{1\}\text{-SE chain of } M'_i \text{ in } \mathcal{B}_{i+1}\} \\ &\quad + \#\{\text{left } \{1\}\text{-NE chain of } M'_i \text{ in } B'_i\} - \#\{\text{left } \{1\}\text{-SE chain of } M'_i \text{ in } B'_i\}. \end{aligned}$$

Then Step 2(b) implies that in the filling M_i ,

$$\begin{aligned} \gamma(\{1\}; M) &= \#\{\text{left } \{1\}\text{-NE chain of } M_i\} + \#\{\text{left } \overline{\{1\}}\text{-SE chain of } M_i\} \\ &\quad - \#\{\text{left } \{1\}\text{-NE chain of } M_i \text{ in } \mathcal{B}_i\} + \#\{\text{left } \{1\}\text{-SE chain of } M_i \text{ in } \mathcal{B}_i\}. \end{aligned}$$

Since all the $\{1\}$ -NE (SE) chains of M_i are in $\mathcal{M}_c = B_1 \cup \dots \cup B_k = \mathcal{B}_1$, when $i = 1$ we have $\gamma(\{1\}; M) = \text{se}(M_1) = \text{se}(\phi_\gamma(M))$. Similarly, $\gamma(\overline{\{1\}}; M) = \text{ne}(\phi_\gamma(M))$. ■

Example 4.9. Figure 5 shows an example of the map ϕ_γ applied to a filling M . The filling M is given in the figure on the left, where $|C_1| = |C'_2| = |C'_3| > |C'_4| = |C'_5| > |C'_6|$. Hence $k = 3$, $j_1 = 3$, $j_2 = 5$ and $j_3 = 6$. It is easy to see that $M = M_3 = M'_2$. Figure 5 shows how to get M_2 and M'_1 . In this example, it happens that $M'_1 = M_1$.

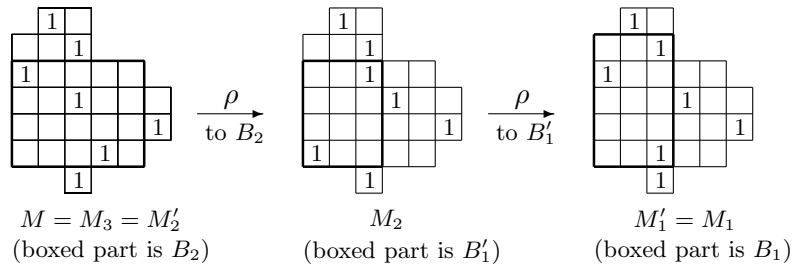

Figure 5: The map ϕ_γ .

Proposition 4.10. Assume $T = \{c_1, c_2, \dots, c_t\} \subseteq [m]$ with $c_1 < c_2 < \dots < c_t$. Let $T' = \{c_1, c_2, \dots, c_{t-1}\}$. Then $G_T^l(p, q) = G_{T'}^l(p, q)$.

Proof. Like Lemma 4.8, Prop. 4.10 can be proved either by analyzing the generating functions, or by a bijection built on the map ϕ_γ . Here we give the details of the bijection which will be used in Section 5.

Let $U = \{C_i : 1 \leq j < c_t\}$ be the set of columns on the left of column C_{c_t} , and V be the set of remaining columns. For any $M \in \mathbf{F}(\mathcal{M}, \mathbf{e}, \mathbf{s})$, let $\xi_{c_t}(M)$ be the filling obtained from M by replacing $M \cap V$ with $\phi_\gamma(M \cap V)$. Then ξ_{c_t} is a bijection on $\mathbf{F}(\mathcal{M}, \mathbf{e}, \mathbf{s})$ such that

$$(\gamma(T; M), \gamma(\bar{T}; M)) = (\gamma(T'; \xi_{c_t}(M)), \gamma(\bar{T}'; \xi_{c_t}(M))). \quad (9)$$

The proof is similar to that of Prop. 4.7 and is omitted. \blacksquare

Proof of Theorem 2.3. Assume $T = \{c_1, c_2, \dots, c_t\} \subseteq \mathcal{C}$ with $c_1 < c_2 < \dots < c_t$. Let $\Sigma_\gamma = \xi_{c_1} \circ \xi_{c_2} \circ \dots \circ \xi_{c_t}$, where ξ_c is defined in the proof of Prop. 4.10. Then Σ_γ is a bijection on $\mathbf{F}(\mathcal{M}, \mathbf{e}, \mathbf{s})$ with the property that

$$(\gamma(T; M), \gamma(\bar{T}; M)) = (\text{se}(\Sigma_\gamma(M)), \text{ne}(\Sigma_\gamma(M))). \quad \blacksquare$$

5 Invariance Properties

The bi-variate generating function of (ne, se) (cf. Theorem 4.5) implies that the mixed statistics are invariant under any permutation of rows and/or columns. To be more specific, let \mathcal{M} be a moon polyomino. For any moon polyomino \mathcal{M}' obtained from \mathcal{M} by permuting the rows and/or the columns of \mathcal{M} , we have

$$\begin{aligned} & \#\{M \in \mathbf{F}(\mathcal{M}, \mathbf{e}, \mathbf{s}) : \lambda(A; M) = i, \lambda(\bar{A}; M) = j\} \\ &= \#\{M' \in \mathbf{F}(\mathcal{M}', \mathbf{e}', \mathbf{s}') : \lambda(A; M') = i, \lambda(\bar{A}; M') = j\} \end{aligned}$$

for any nonnegative integers i and j , where \mathbf{e}' (resp. \mathbf{s}') is the sequence obtained from \mathbf{e} (resp. \mathbf{s}) in the same ways as the rows (resp. columns) of \mathcal{M}' are obtained from the rows (resp. columns) of \mathcal{M} , and $\lambda(A; M)$ is any of the four statistics $\alpha(S; M)$, $\beta(S; M)$, $\gamma(T; M)$, and $\delta(T; M)$. In this section we present bijective proofs of such phenomena.

Let \mathcal{M} be a general moon polyomino. Let \mathcal{N}_l be the unique left-aligned moon polyomino whose sequence of row lengths is equal to $|R_1|, \dots, |R_n|$ from top to bottom. In other words, \mathcal{N}_l is the left-aligned polyomino obtained by rearranging the columns of \mathcal{M} by length in weakly decreasing order from left to right. We shall use an algorithm developed in [5] that rearranges the columns of \mathcal{M} to generate \mathcal{N}_l .

The algorithm α for rearranging \mathcal{M} :

Step 1 Set $\mathcal{M}' = \mathcal{M}$.

Step 2 If \mathcal{M}' is left aligned, go to Step 4.

Step 3 If \mathcal{M}' is not left-aligned, consider the largest rectangle \mathcal{B} completely contained in \mathcal{M}' that contains C_1 , the leftmost column of \mathcal{M}' . Update \mathcal{M}' by setting \mathcal{M}' to be the polyomino obtained by moving the leftmost column of \mathcal{B} to the right end. Go to Step 2.

Step 4 Set $\mathcal{N}_l = \mathcal{M}'$.

Figure 6 is an illustration of the algorithm α .

Based on the algorithm α , Chen et al. constructed a bijection $g = g_{\mathcal{M}} : \mathbf{F}(\mathcal{M}, \mathbf{e}, \mathbf{s}) \rightarrow \mathbf{F}(\mathcal{N}_l, \mathbf{e}, \mathbf{s}')$ such that $(\text{se}(M), \text{ne}(M)) = (\text{se}(g(M)), \text{ne}(g(M)))$, see [5, Section 5.3.2].

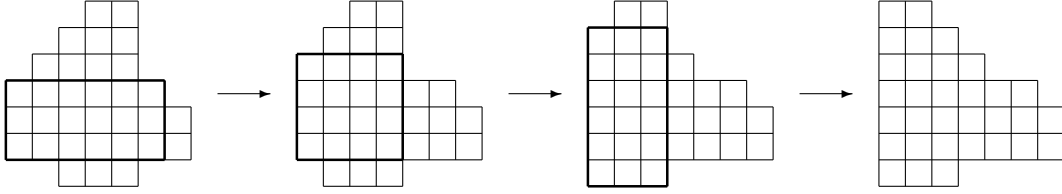

Figure 6: The algorithm α .

Combining $g_{\mathcal{M}}$ with the bijection Θ_{α} constructed in the proof of Theorem 2.1, we are led to the following invariance property.

Theorem 5.1. *Let \mathcal{M} be a moon polyomino. For any moon polyomino \mathcal{M}' obtained from \mathcal{M} by permuting the columns of \mathcal{M} , the map*

$$\Phi_{\alpha} = \Theta_{\alpha}^{-1} \circ g_{\mathcal{M}'}^{-1} \circ g_{\mathcal{M}} \circ \Theta_{\alpha} : \mathbf{F}(\mathcal{M}, \mathbf{e}, \mathbf{s}) \rightarrow \mathbf{F}(\mathcal{M}', \mathbf{e}, \mathbf{s}') \quad (10)$$

is a bijection with the property that

$$(\alpha(S; M), \alpha(\bar{S}; M)) = (\alpha(S; M'), \alpha(\bar{S}; M')).$$

Similarly, let \mathcal{N}_t be the top aligned polyomino obtained from \mathcal{M} by rotating 90 degrees counterclockwise first, followed by applying the algorithm α , and finally rotating 90 degrees clockwise. Such operations enable us to establish a bijection $h = h_{\mathcal{M}}$ from $\mathbf{F}(\mathcal{M}, \mathbf{e}, \mathbf{s})$ to $\mathbf{F}(\mathcal{N}_t, \mathbf{e}', \mathbf{s})$ that keeps the statistics (se, ne) . The map $h_{\mathcal{M}}$ can be described by using the map $g_{\mathcal{M}}$ under the algorithm α with a rotation of 90 degrees clockwise. More precisely, the rotated algorithm α' is the same as the algorithm α , except that the term *left-aligned* is replaced with the term *top-aligned*, C_1 is replaced with R_1 , and *left* and *right* are replaced with *top* and *bottom* respectively. In fact the map $h_{\mathcal{M}}$ is much simpler than $g_{\mathcal{M}}$ since every row in the filling has at most one 1-cell. We state it in full detail for completeness.

Theorem 5.2. *There is a bijection $h_{\mathcal{M}}: \mathbf{F}(\mathcal{M}, \mathbf{e}, \mathbf{s}) \rightarrow \mathbf{F}(\mathcal{N}_t, \mathbf{e}', \mathbf{s})$ such that $(se(M), ne(M)) = (se(h(M)), ne(h(M)))$.*

Proof. Let $M \in \mathbf{F}(\mathcal{M}, \mathbf{e}, \mathbf{s})$. To obtain $h_{\mathcal{M}}(M)$, we perform the rotated algorithm α' to transform the shape \mathcal{M} to \mathcal{N}_t and change the filling when we move rows down in Step 3 so that the number of 1's in each row and column is preserved.

Let N be the filling on the rectangular \mathcal{B} in Step 3 of the rotated algorithm α' that contains the row R_1 of the current filling. Let \mathcal{B}' be the rectangle obtained by moving the row R_1 from top to the bottom of \mathcal{B} . Fill it to obtain a filling N' as follows.

1. If R_1 is empty, then N' is obtained from $N \setminus \{R_1\}$ by adding an empty row at the bottom.
2. If R_1 has a 1-cell,
 - (a) The rows that are empty in \mathcal{B} remain empty in \mathcal{B}' . Shade these rows in both \mathcal{B} and \mathcal{B}' .
 - (b) The filling on the rectangle formed by the un-shaded rows of \mathcal{B}' is the same as N restricted to the rectangle obtained from the un-shaded rows of \mathcal{B} .

The filling outside \mathcal{B} remains unchanged.

Applying the rotated algorithm α' with the above operations on filling M , we finally obtain the filling $h_{\mathcal{M}}(M)$. The proof of [5, Prop. 5.10] ensures that $h_{\mathcal{M}}$ is a bijection. \blacksquare

Combining the bijection Θ_α with $h_{\mathcal{M}}$, we arrive at the second invariance property.

Theorem 5.3. *Let \mathcal{M} be a moon polyomino. For any moon polyomino \mathcal{M}' obtained from \mathcal{M} by permuting the rows of \mathcal{M} , the map*

$$\Lambda_\alpha = \Theta_\alpha^{-1} \circ h_{\mathcal{M}'}^{-1} \circ h_{\mathcal{M}} \circ \Theta_\alpha : \mathbf{F}(\mathcal{M}, \mathbf{e}, \mathbf{s}) \rightarrow \mathbf{F}(\mathcal{M}', \mathbf{e}', \mathbf{s}) \quad (11)$$

is a bijection with the property that

$$(\alpha(S; M), \alpha(\bar{S}; M)) = (\alpha(S; M'), \alpha(\bar{S}; M')).$$

It is evident that replacing Θ_α with the map Σ_γ defined in the proof of Theorem 2.3 in (10) and (11) leads to bijections preserving the statistics $(\gamma(T; M), \gamma(\bar{T}; M))$ under any permutation of columns or rows. Similar results hold for the statistics $\beta(S; M)$ and $\delta(T; M)$ by reflecting the moon polyomino with respect to a horizontal or a vertical line.

References

- [1] D. Chebikin, Variations on descents and inversions in permutations, *Electron. J. Combin.* 15 (2008) R132.
- [2] W. Y. C. Chen, E. Y. P. Deng, R. R. X. Du, R. P. Stanley and C. H. Yan, Crossings and nestings of matchings and partitions, *Trans. Amer. Math. Soc.* 359 (2007) 1555–1575.
- [3] W. Y. C. Chen, I. M. Gessel, C. H. Yan and A. L. B. Yang, A major index for matchings and set partitions, *J. Combin. Theory Ser. A* 115 (2008) 1069–1076.
- [4] W. Y. C. Chen, S. Y. Wu and C. H. Yan, Linked partitions and linked cycles, *European J. Combin.* 29 (2008) 1408–1426.
- [5] W. Y. C. Chen, S. Poznanović, C. H. Yan and A. L. B. Yang, Major index for 01-fillings of moon polyominoes, [arXiv:math.CO/0902.3637](https://arxiv.org/abs/math/0902.3637).
- [6] A. de Mier, On the symmetry of the distribution of crossings and nestings in graphs, *Electron. J. Combin.* 13 (2006), N21.
- [7] A. de Mier, k -noncrossing and k -nonnesting graphs and fillings of Ferrers diagrams, *Combinatorica* 27 (2007) 699–720.
- [8] M. de Sainte-Catherine, *Couplages et Pfaffiens en Combinatoire, Physique et Informatique*, Ph.D. Thesis, University of Bordeaux I, Talence, France, 1983.
- [9] J. Jonsson, Generalized triangulations and diagonal-free subsets of stack polyominoes, *J. Combin. Theory Ser. A* 112 (2005), 117–142.
- [10] A. Kasraoui, Ascents and descents in 01-fillings of moon polyominoes, *European J. Combin.*, to appear.
- [11] A. Kasraoui and J. Zeng, Distributions of crossings, nestings and alignments of two edges in matchings and partitions, *Electron. J. Combin.* 13 (2006) R33.

- [12] M. Klazar, On identities concerning the numbers of crossings and nestings of two edges in matchings, *SIAM J. Discrete Math.* 20 (2006) 960–976.
- [13] C. Krattenthaler, Growth diagrams, and increasing and decreasing chains in fillings of Ferrers shapes, *Adv. in Appl. Math.* 37 (2006), 404–431.
- [14] A. Mendes, J. Remmel, Descents, inversions, and major indices in permutation groups, *Discrete Math.* 308 (2008) 2509–2524.
- [15] S. Poznanović, C. H. Yan, Crossings and nestings of two edges in set partitions, *SIAM J. Discrete Math.*, to appear.
- [16] M. Rubey, Increasing and decreasing sequences in fillings of moon polyominoes, [arXiv:math.CO/0604140](https://arxiv.org/abs/math/0604140).