

Stabilizing Effect of Diffusion in Enhanced Oil Recovery and Three-Layer Hele-Shaw Flows with Viscosity Gradient

Prabir Daripa^{1,*} and G. Paşa²

¹Department of Mathematics, Texas A&M University, College Station, TX-77843

²Institute of Mathematics “Simion Stoilow” of Romanian Academy, Bucharest, RO-70700

Abstract

In the presence of diffusion, stability of three-layer Hele-Shaw flows which models enhanced oil recovery processes by polymer flooding is studied for the case of variable viscosity in the middle layer. This leads to the coupling of the momentum equation and the species advection-diffusion equation the hydrodynamic stability study of which is presented in this paper.

Linear stability analysis of a potentially unstable three-layer rectilinear Hele-Shaw flow is used to examine the effects of species diffusion on the stability of the flow. Using a weak formulation of the disturbance equations, upper bounds on the growth rate of individual disturbances and on the maximal growth rate over all possible disturbances are found. Analytically, it is shown that a short-wave disturbance if unstable can be stabilized by mild diffusion of species where as an unstable long-wave disturbance can always be stabilized by strong diffusion of species. Thus, an otherwise unstable three-layer Hele-Shaw flow can be completely stabilized by a large enough diffusion, i.e., by increasing enough the magnitude of the species diffusion coefficient. The magnitude of this diffusion coefficient required to completely stabilize the flow will depend on the magnitude of interfacial viscosity jumps and the viscosity gradient of the basic viscous profile of the middle layer.

Keywords: Three-layer Hele-Shaw flows, Improved oil recovery, Stability of flows, Sturm-Liouville problem, Upper bound.

*Author for correspondence (e-mail: prabir.daripa@math.tamu.edu)

1 Introduction

Diffusion processes occur in many physical phenomena such as multi-phase flows, parallel flows, mixing layers, solidification of multi-component systems, just to name a few. Efficient design of some of the processes involving such flows requires, among others, knowledge of stability characteristics of these flows and their dependence on the diffusion coefficient and other parameters of the problem. This is important because the presence of diffusion can significantly modify the stability properties of some of these flows, so much so that in some cases this can alter the way these processes involving diffusion are designed. Some insight on why the diffusion can do so can be gained at times by investigating the nature of underlying equations with and without diffusion. A problem such as the one we deal with in this paper is scale invariance for the zero diffusion case but not so when the diffusion comes into play (see below the problem (1)-(3) subject to appropriate initial and boundary data for scale-invariance). Therefore, many nonlinear structures that may persist approximately on all scales for the zero diffusion case may not do so when diffusion is present. It is of significant interest to understand how nonlinear structures behave at different scales and correlation of statistical properties of these structures on various scales. A first step towards such nonlinear studies is to formulate and carefully evaluate the role of diffusion on the stability of equilibrium solutions of these problems with diffusion present. This is the subject matter of this paper in the context of interfacial instability in three-layer Hele-Shaw flows.

Interfacial instabilities and ensuing fingering phenomena (which refers to the development of coherent structures in the form of fingers and their interaction leading to merging and breaking of such structures and ensuing mixing layers) occur in a host of diverse fields, such as in oil recovery, in crystal growth, and in Crab Nebula one of the most famous supernova remnants, just to name a few. The interfacial instabilities in these examples are of different types depending on the forces driving them: Rayleigh-Taylor ('RT' for short) instability appears in supernova remnants, Mullins-Sekerka instability occurs in crystal growth, and Saffman-Taylor ('ST' for short) instability occurs in oil recovery processes. These instabilities are driven by different physical mechanisms. For example, the ST instability occurs at the interface between two immiscible fluids when a low viscous fluid displaces a high viscous fluid, a typical scenario in secondary oil recovery. The ideas and analysis presented here in the context of three-layer interfacial flows may be applicable after some ingenuity to these related instabilities.

Viscosity driven instability in two-layer immiscible flows was first studied by Saffman & Taylor (1958) in a Hele-Shaw cell and by Chouke et. al. (1959) almost about the same time in porous media, though Hill (1952) had studied the one dimensional case earlier. The interface displacing the more viscous fluid in these flows is well known to be linearly unstable to all disturbances in the absence of surface tension. Surface tension stabilizes only the short waves. This problem is inherently unstable with or without surface tension. In the nonlinear regime, very often an initially

planar interface participates in the process of fingering phenomena resulting either in one or more disjoint interfaces with complex topology or a single finger penetrating at a constant speed into the more viscous fluid region. There have been many numerical, analytical, and experimental studies on various aspects of this problem such as: construction of exact steady state solutions of Hele-Shaw flow equations, existence and uniqueness of steady state solutions with and without surface tension, selection mechanism of fingers, possibility of singularity formation in initial value calculation with and without surface tension, large time behavior of the interfacial evolution from arbitrary initial data and ensuing statistical properties of the possible chaotic solutions. For example, for the zero surface tension case exact “finger” (smooth) solution was first given by Saffman & Taylor (1958) and cusp development (singular) was given by Howison (1986). Exact solution for the non-zero surface tension case has been given by Kadanoff (1990) and Vasconcelos & Kadanoff (1991). There are also other studies on solutions with surface tension some of which are by Escher & Simonett (1996, 1997), Su (2001); Xie & Tanveer (2003); and Tanveer & Xie (2003), just to cite a few. Existence of general solutions with surface tension has been addressed by several authors including Duchon & Robert (1984), and Otto & Weinan (1997). The possibility of formation of singularities for the non-zero surface tension case has been addressed by Tian (1996) and Nie & Tian (1998) who also studies the zero-surface tension case. There are many who have made contributions in these aspects of the problem. For some of these contributions, we direct the readers to some review and/or focussed articles: (Chouke et al. (1959), Saffman (1986), Homsy (1987), Kessler & Levine (1988), Tanveer (2000)). Towards this end, it is also worth citing some numerical and perturbation studies on this problem such as that of McLean & Saffman (1981) and Almgren (1995).

There have been many studies on the effects of diffusion on stability characteristics of various types of fluid flows such as free shear flows (see [22]), miscible Hele-Shaw and porous media flows (see [10], [17], [27], and [37]), just to name a few. In all these flows, diffusion of species does not affect the viscosity of species-bearing fluid unlike the case in this paper. In this paper, we analytically study the role of diffusion of species on the stability properties of unstable three-layer Hele-Shaw flows with middle layer having a variable viscosity profile. The diffusion here has special significance which is explained later in this section. This is an idealized model of EOR (enhanced oil recovery) process by polymer flooding in which the leading layer of oil is displaced by a more mobile polymer solution (polymer-laden-water) phase which, in turn, is displaced by even more mobile water phase. This is a three-layer multi-phase flow in porous media with oil and water having constant viscosities and the in-between layer having a viscosity that depends on the concentration of polymer. The purpose of the middle layer with increased viscosity is to stabilize the unstable leading interface that is displacing the oil, thereby improving oil recovery. This displacement process involves nonlinear interaction of two potentially unstable interfaces and a potentially unstable middle layer. A study on the hydrodynamic stability of this three-layer process is a step towards a better design and understanding of this process.

Hydrodynamic stability studies of the above process is somewhat complex due to underlying structure of the equations that model this problem. For passive advection of polymer without any diffusion or adsorption effects, a system of coupled elliptic-hyperbolic equations effectively models this problem, see Daripa et. al. (1988). According to this model, the underlying wave structure for a constant viscosity (i.e., constant concentration) middle-layer displacing oil consists of a shock-type discontinuity as the leading oil displacing interface, a contact-type discontinuity as the trailing interface separating water phase from the middle-layer poly-solution, and rarefaction waves in saturation behind the leading interface. These rarefaction waves essentially changes the initial constant viscosity of the middle layer to a graded viscosity decreasing monotonically behind the leading interface. With increasing time these rarefaction waves travel further into the middle layer away from the leading interface thereby constantly modifying the viscosity profile of the middle-layer with viscosity gradient remaining positive in the direction of displacement. From viscous profile consideration then each of the two interfaces and the middle layer are individually unstable. However, stability characteristic of the combined set-up in which all these three distinct instabilities interact is not well-understood due to the complex nature of the elliptic-hyperbolic system modeling this process. In Daripa et.al. (1988), the initial value problem of the above set-up was solved numerically using a front-tracking method. It will be interesting and useful to gain some understanding analytically of the hydrodynamic stability issues associated with this process, such as the interaction and instability transfer mechanism between these three instabilities. In order to make progress in this direction without losing any of the physical phenomena at play in this problem, we instead study this three-layer process in a Hele-Shaw cell with variable viscosity middle layer. Replacing a porous medium by Hele-Shaw cell essentially amounts to replacing the shock-type leading interface by a material interface without any complication of rarefaction waves some effects of which will, anyway, be captured by the graded viscosity of the middle layer in the Hele-Shaw cell.

The stability characteristics of this three-layer Hele-Shaw problem was recently analyzed by Daripa & Pasa (2006)). In this model, viscosities of the extreme layer fluids are constants and polymer concentration in the poly-solution of the middle layer is taken to be non-uniform so that middle-layer has a non-constant viscosity profile. In this work, the authors neglect diffusion of polymer allowing only advection of polymer with the fluid. The viscosity profile in the entire set-up is initially such that each of the two interfaces as well as the middle-layer are individually unstable. A linear stability analysis of a uniform flow in this three-layer Hele-Shaw cell is presented in Daripa & Pasa (2006). There it is shown that even within linear theory, the interaction between the interfaces prevails regardless of how weak the interfacial disturbances are. We specifically derived an upper bound on the maximal growth rate of disturbances and discussed its implications. In particular, the upper bound derived in Daripa & Pasa (2006) identifies that the growth rate of disturbances in the combined three-layer set-up is smaller than the larger of (i) the upper bounds

on “effective” growth rates of the two interacting interfaces each of which exceeds its own individual S-T growth rate, and (ii) an upper bound of the growth rate of disturbances within the central fluid layer.

In the stability analysis presented here, we incorporate the effect of diffusion of polymer into the above three-layer set-up in a Hele-Shaw cell. Nature of diffusion here is much different than diffusion of momentum at molecular level modeled by viscosity in the Navier-Stokes (NS) equation. Thus many of the results on stability of various flows known in the context of NS equation do not apply directly here. As we know, even for NS flows the viscous diffusion term in the equation does not always help stabilizing a flow. For example, it is well known that parallel Navier-Stokes flows in the inviscid limit of viscous unstable flow is stable meaning that viscosity is a destabilizing phenomena in these parallel flows which is contrary to intuition. For the case of polymer diffusion process present in the middle-layer of this three-layer Hele-Shaw flows, viscosity of fluid particles in the poly-solution will change with changes in the polymer concentration due to diffusion. It is not transparent whether this viscosity change (taking place in the middle layer during a flow process) will help or hinder stabilization of the flow. In this paper, we establish some precise results on this effect of viscosity change on the stability of basic flow.

The paper is laid out as follows. In section 2, we formulate the problem. In section 3, we obtain an upper bound result and several theorems on the stability of the flow and discuss their implications. Finally, we briefly conclude in section 5.

2 Problem Formulation

We consider two-dimensional fluid flows in a three-layer Hele-Shaw cell. The set-up is shown in Fig. 1. Because of the symmetry of the flow in the z -direction, the flow is essentially two-dimensional. Therefore, the domain of interest is $\Omega := (x, y) = \mathbb{R}^2$ (with a periodic extension of the set-up in the y -direction). The fluid upstream (i.e., as $x \rightarrow -\infty$) has a velocity $\mathbf{u} = (U, 0)$. The fluid in the left layer with viscosity μ_l extends up to $x = -\infty$, the fluid in the right layer with viscosity μ_r extends up to $x = \infty$, and the fluid in-between middle-layer of length L has a smooth viscous profile $\mu(x)$ such that $\mu_l < \mu(x) < \mu_r$. One of the ways to have a smooth viscous profile of the middle-layer fluid is to use polymer-thickened-water in the middle-layer. Here and below we call this polymer-thickened-water as ‘poly-solution’. The polymer increases the viscosity of the water in proportion to its concentration and it is assumed that the viscosity μ of the poly-solution is an invertible function of polymer concentration c which is a realistic assumption. In our set-up, the polymer concentration in the middle layer is gradually increasing in the direction of displacement. Therefore the middle-layer has a smooth viscous profile $\mu(x)$ such that $\mu_l < \mu(x) < \mu_r$, $-L < x < 0$.

In the middle layer, the polymer concentration c is not uniform initially and how concentration

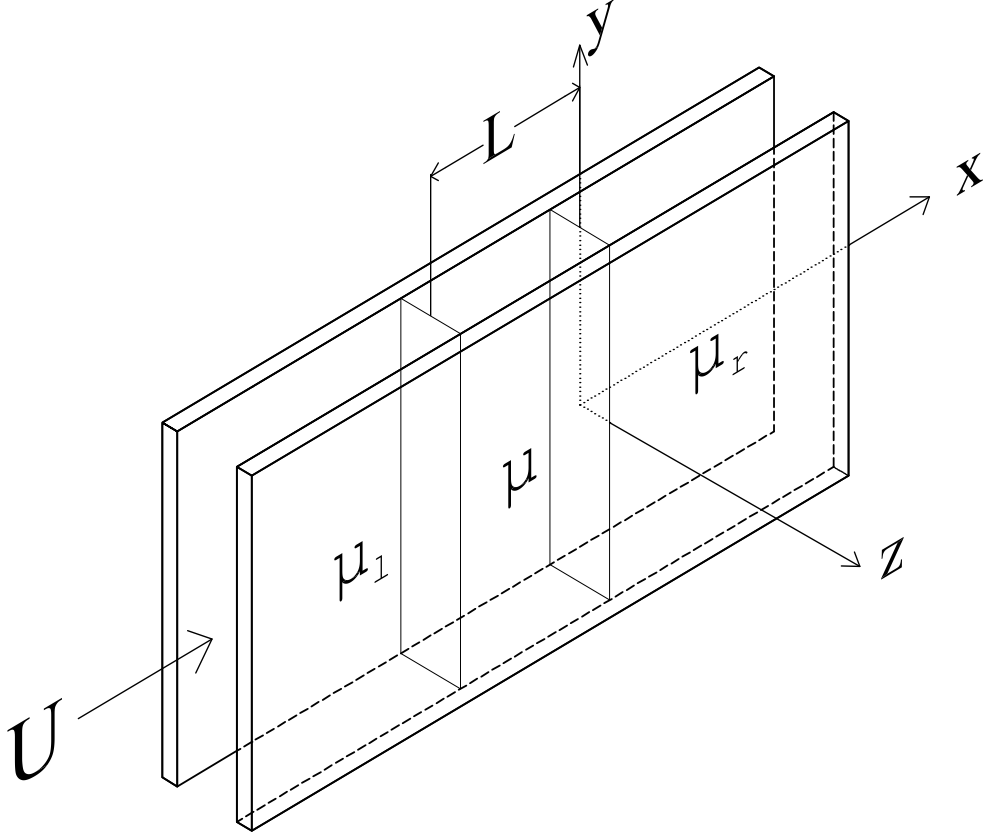

Figure 1: Three-layer fluid flow in a Hele-Shaw cell

c changes in time and space in the middle layer is governed by advection-diffusion equation:

$$\frac{\partial c}{\partial t} + \mathbf{u} \cdot \nabla c = \eta \Delta c,$$

where η , the diffusion coefficient, is a constant. Since viscosity μ is an invertible function of concentration c , the same equation holds true in the middle layer for viscosity $\mu(x)$ in the middle

layer. Therefore, the underlying equations of this problem are

$$\nabla \cdot \mathbf{u} = 0, \quad (1)$$

$$\nabla p = -\mu \mathbf{u}, \quad (2)$$

$$\frac{\partial \mu}{\partial t} + \mathbf{u} \cdot \nabla \mu = \eta \Delta \mu, \quad (3)$$

where $\nabla = \left(\frac{\partial}{\partial x}, \frac{\partial}{\partial y} \right)$ and Δ is Laplacian in the plane. The first equation (1) is the continuity equation for incompressible flow, the second equation (2) is the Darcy's law (Darcy (1856)), and the third equation (3) is the advection-diffusion equation for viscosity. For the zero-diffusion case, please see Gorell & Homsy (1983), and Daripa & Pasa (2005).

The above system (1)-(3) admits a simple basic solution, namely the whole fluid set-up moves with speed U in the x direction and the two interfaces, namely the one separating the left layer from the middle-layer and the other separating the right layer from the middle-layer, are planar, i.e. parallel to the y -axis. The viscous profile in the middle layer is taken to be linear consistent with the equation (3). The pressure corresponding to this basic solution is obtained by integrating (2). In a frame moving with velocity $(U, 0)$, the set-up corresponding to the above basic solution is stationary along with two planar interfaces separating these three fluid layers and the middle layer having linear viscous profile. **Here and below, with slight abuse of notation, the same variable x is used to refer to the x -coordinate in the moving reference frame.** This is also necessary in order to preserve continuity of notation used in [5], [6] which facilitates comparison of results obtained in this paper (which has diffusion) with that in [6] (which has no diffusion).

For the purpose of linear stability analysis below, the basic linear viscous profile of the middle-layer is chosen as follows: $\mu(x) = a x + b$, $\mu_l < \mu(-L) < \mu(0) < \mu_r$ with $\mu = \mu_l$ for $x < -L$ and $\mu = \mu_r$ for $x > 0$. See Fig. 1. The left and right limit viscosities in the middle layer are respectively $\mu(-L)$ and $\mu(0)$. Note that by definition, $a = (\mu(0) - \mu(-L))/L > 0$ and $b = \mu(0)$. As we know from our earlier studies that this set-up is inherently linearly unstable in the absence of diffusion (see Daripa & Pasa (2006)). Here, we study linear stability of this set-up in the presence of diffusion.

In the moving frame, the basic solution $(u = 0, v = 0, p_0(x), \mu(x))$ is perturbed by $(\epsilon \tilde{u}, \epsilon \tilde{v}, \epsilon \tilde{p}, \epsilon \tilde{\mu})$, where ϵ is a small parameter. We write equations (1) through (3) in the above moving frame and then substitute the perturbed variables in these modified equations. We equate to zero the coefficients of the small parameter ϵ to obtain the following linearized equations for $\tilde{\mathbf{u}} = (\tilde{u}, \tilde{v})$, \tilde{p} , and $\tilde{\mu}$.

$$\nabla \cdot \tilde{\mathbf{u}} = 0, \quad x, y \in \mathbb{R}, \quad (4)$$

$$\nabla \tilde{p} = -\mu \tilde{\mathbf{u}} - \tilde{\mu} (U, 0), \quad x, y \in \mathbb{R}, \quad (5)$$

$$\frac{\partial \tilde{\mu}}{\partial t} + \tilde{u} \frac{d\mu}{dx} = \eta \Delta \tilde{\mu}, \quad -L < x < 0. \quad (6)$$

The basic flow is essentially two-dimensional. Since such a flow can be subjected to three- as well as two-dimensional disturbance, it makes sense to study the effect of two-dimensional disturbance first which is what we do in this paper. We study the temporal evolution of arbitrary perturbations by the method of normal modes. Hence, we consider a typical wave component of the form

$$(\tilde{u}, \tilde{v}, \tilde{p}, \tilde{\mu}) = (f(x), \psi(x), \phi(x), h(x)) e^{(i k y + \sigma t)}, \quad (7)$$

where k is a real axial wavenumber, and σ is the growth rate which could be complex. We substitute (7) in (4) through (6), and obtain equations involving $f(x)$, $\psi(x)$, $\phi(x)$, and $h(x)$. After some algebraic manipulation of these resulting equations in $f(x)$, $\psi(x)$, $\phi(x)$, and $h(x)$, we obtain two coupled equations (see equations (8)₁ and (8)₂ below) involving $f(x)$ and $h(x)$ which are subject to boundary conditions resulting from linearization of the kinematic and dynamic boundary conditions at the two interfaces as derived in Daripa & Pasa (2006) for the zero-diffusion case. These boundary conditions are independent of diffusion process in the middle layer. Thus, in this model where the viscosity is advected as well as diffused by the fluid in the middle layer, the evolution of linearized disturbances at the interface is governed by the following problem.

$$\left. \begin{aligned} -(\mu f_x)_x + k^2 \mu f &= -k^2 U h, & x \in (-L, 0), \\ \eta h_{xx} - (\sigma + \eta k^2) h &= a f, & a > 0, \quad x \in (-L, 0), \\ f_x(0) &= (\lambda \mathcal{P} + q) f(0), & f_x(-L) = (\lambda r + s) f(-L), \\ h(0) &= h(-L) = 0, \end{aligned} \right\} \quad (8)$$

where $\lambda = 1/\sigma$, $a = (\mu(0) - \mu(-L))/L > 0$, $\eta > 0$, and \mathcal{P} , q , r , s are defined by

$$\left. \begin{aligned} \mathcal{P} &= \{[\mu]_r U k^2 - T k^4\} / \mu(0), & q &= -\mu_r k / \mu(0) \leq 0, \\ r &= \{-[\mu]_l U k^2 + S k^4\} / \mu(-L), & s &= \mu_l k / \mu(-L) \geq 0. \end{aligned} \right\} \quad (9)$$

where $[\mu]_r = (\mu_r - \mu(0))$ and $[\mu]_l = (\mu(-L) - \mu_l)$. It is worth noting that

$$\mathcal{P} \geq 0 \quad \text{for } k^2 \leq k_1^2 = [\mu]_r U / T, \quad r \leq 0 \quad \text{for } k^2 \leq k_2^2 = [\mu]_l U / S. \quad (10)$$

All these equations are in dimensional form. In (9), T is the surface tension at the interface $x = 0$ and S is the surface tension at the interface $x = -L$. It may be worth mentioning that the term involving U in equation (5) gets transformed into the term on the right-hand side of equation (8)₁ which is easy to see upon deriving (8) from (4)-(6) by simple algebraic manipulation.

Below, we carry out analysis of this problem to derive an upper bound on the growth rate and discuss its implication in stabilizing an otherwise unstable three-layer set-up in a Hele-Shaw cell.

3 An Upper Bound

We multiply the equation (8)₁ by f^* (the complex conjugate of f) and upon integrating over $(-L, 0)$, using the boundary conditions defined in problem (8), yields

$$\begin{aligned} & \mu(-L)(r/\sigma + s) |f(-L)|^2 - \mu(0)(\mathcal{P}/\sigma + q)|f(0)|^2 + \int_{-L}^0 \mu |f_x|^2 dx \\ & + k^2 \int_{-L}^0 \mu |f|^2 dx = -k^2 U \int_{-L}^0 h f^* dx. \end{aligned} \quad (11)$$

Rearranging, we obtain

$$\begin{aligned} & \sigma \left\{ -q\mu(0)|f(0)|^2 + s\mu(-L)|f(-L)|^2 + \int_{-L}^0 \mu |f_x|^2 dx + k^2 \int_{-L}^0 \mu |f|^2 dx \right\} - \\ & - \mathcal{P}\mu(0)|f(0)|^2 + r\mu(-L)|f(-L)|^2 = -k^2 U \sigma \int_{-L}^0 h f^* dx. \end{aligned} \quad (12)$$

Multiplying equation (8)₂ by f^* and then integrating yields

$$\eta \int_{-L}^0 h_{xx} f^* dx - (\sigma + k^2 \eta) \int_{-L}^0 h f^* dx = a \int_{-L}^0 |f|^2 dx. \quad (13)$$

Rearranging and after multiplication with $k^2 U$ we obtain

$$k^2 U a \int_{-L}^0 |f|^2 dx + k^4 U \eta \int_{-L}^0 h f^* dx - k^2 U \eta \int_{-L}^0 h_{xx} f^* dx = -k^2 U \sigma \int_{-L}^0 h f^* dx. \quad (14)$$

Therefore, right hand sides of equations (12) and (14) are equal from which we obtain

$$\begin{aligned} \sigma = & \frac{\mathcal{P}\mu(0)|f(0)|^2 - r\mu(-L)|f(-L)|^2 + a k^2 U \int_{-L}^0 |f|^2 dx}{H} - \\ & - k^2 U \eta \frac{k^2 \int_{-L}^0 (-h) f^* dx + \int_{-L}^0 h_{xx} f^* dx}{H}. \end{aligned} \quad (15)$$

where

$$H = -q\mu(0)|f(0)|^2 + s\mu(-L)|f(-L)|^2 + \int_{-L}^0 \mu |f_x|^2 dx + k^2 \int_{-L}^0 \mu |f|^2 dx > 0. \quad (16)$$

We introduce the following notations.

$$\int_{-L}^0 f(-h)^* dx = F_1 + iF_2, \quad \sigma = \sigma_R + i\sigma_I. \quad (17)$$

$$G = \text{real} \left(\int_{-L}^0 h_{xx} f^* dx \right). \quad (18)$$

Then real part of (15) gives

$$\sigma_R = \frac{\mathcal{P}\mu(0)|f(0)|^2 - r\mu(-L)|f(-L)|^2 + a k^2 U \int_{-L}^0 |f|^2 dx}{H} - k^2 U \eta \frac{k^2 F_1 + G}{H}. \quad (19)$$

Theorem 1. *We have*

$$\sigma_R \leq \max \left\{ \frac{2T}{\mu_r} \left(\frac{U[\mu]_r}{3T} \right)^{3/2}, \frac{2S}{\mu_l} \left(\frac{U[\mu]_l}{3S} \right)^{3/2}, \frac{aU}{\mu_l} \right\} - k^2 U \eta \frac{k^2 F_1 + G}{H}. \quad (20)$$

Proof. We neglect the positive term $\int_{-L}^0 \mu |f_x|^2$ in the expression (16) of H . Moreover, we have $\mu \geq \mu_l$, then

$$H \geq s\mu(-L)|f(-L)|^2 - q\mu(0)|f(0)|^2 + k^2 \mu_l \int_{-L}^0 |f|^2 > 0 \quad (21)$$

and from (19) we have

$$\sigma_R \leq \frac{-r\mu(-L)|f(-L)|^2 dx + \mathcal{P}\mu(0)|f(0)|^2 + k^2 U a \int_{-L}^0 |f|^2 dx}{s\mu(-L)|f(-L)|^2 dx - q\mu(0)|f(0)|^2 + k^2 \mu_l \int_{-L}^0 |f|^2 dx} - k^2 U \eta \frac{k^2 F_1 + G}{H} \quad (22)$$

We use the following well known inequality when all B_i are positive.

$$\frac{A_1 + A_2 + \dots + A_n}{B_1 + B_2 + \dots + B_n} \leq \max \left\{ \frac{A_i}{B_i} \right\}$$

Then for $n = 3$ the above inequality and (22) give us

$$\sigma_R \leq \max \left\{ \left(\frac{\mathcal{P}}{-q} \right), \left(\frac{-r}{s} \right), \frac{aU}{\mu_l} \right\} - k^2 U \eta \frac{k^2 F_1 + G}{H}. \quad (23)$$

Since $\mathcal{P}/(-q)$ and $(-r)/s$ depend on the wave-number k according to the definitions (9) of these parameters, this inequality (23) gives the modal upper bound on the growth rate (i.e., the upper bound on the growth rate of a disturbance with wave-number k). In terms of the parameters of the problem, the following inequality also follows.

$$\begin{aligned} \sigma_R &\leq \max \left\{ \max_k \left(\frac{\mathcal{P}}{-q} \right), \max_k \left(\frac{-r}{s} \right), \frac{aU}{\mu_l} \right\} - k^2 U \eta \frac{k^2 F_1 + G}{H} \\ &= \max \left\{ \frac{2T}{\mu_r} \left(\frac{U[\mu]_r}{3T} \right)^{3/2}, \frac{2S}{\mu_l} \left(\frac{U[\mu]_l}{3S} \right)^{3/2}, \frac{aU}{\mu_l} \right\} - k^2 U \eta \frac{k^2 F_1 + G}{H}, \end{aligned} \quad (24)$$

where we have calculated the $\max_k(\mathcal{P}/-q)$ and $\max_k(-r/s)$ using (9). \square

Since only the last term in (24) depends on the wave-number k , right hand side of the inequality (24) gives “modal upper bound” similar to (23). However, the inequality (23) is a better one since it is a stronger upper bound for individual disturbances.

Note that the modal upper bound (24) for the case of no diffusion (i.e., $\eta = 0$) is an absolute upper bound (i.e. over all disturbances regardless of wavenumbers) since the only k -dependent term in (24) drops out in this case, thus recovering the result we have reported Daripa & Pasa (2006) for the zero-diffusion case. Note that this result on the upper bound, however, should not be viewed as transparent based on the intuition that the diffusion in general stabilizes a flow because there are well known results contrary to this intuition. For example, it is well known that parallel

Navier-Stokes flows in the inviscid limit of viscous unstable flow is stable meaning that viscosity is a destabilizing phenomena in these parallel flows which is contrary to intuition.

Role of diffusion: The inequality (20) implies that the upper bound on the growth rate will be less with diffusion than without diffusion for every disturbance provided one of the two, F_1 and G , is positive and the other one is non-negative. (We already know $H > 0$ from (16)). We establish this fact below for unstable modes. This will establish that diffusion reduces the growth rate of unstable modes in the sense of upper bound.

Assumption 3.1. *There are unstable modes (i.e. modes with $\text{real}(\sigma) > 0$). We will show this a posteriori using the second proposition below.*

Lemma 1. *If $\sigma_R > 0$, we have*

$$F_1 > 0, \quad G \geq 0. \quad (25)$$

Proof. We multiply (8)₂ by h^* and integrate over $(-L, 0)$. We use (8)₄, namely $h(0) = h(-L) = 0$, and obtain:

$$-\eta \int_{-L}^0 |h_x|^2 dx - (\sigma + k^2\eta) \int_{-L}^0 |h|^2 dx = a \int_{-L}^0 f h^* dx. \quad (26)$$

The real and imaginary parts of this equation give

$$\sigma_R + k^2\eta = \frac{a F_1 - \eta \int_{-L}^0 |h_x|^2 dx}{\int_{-L}^0 |h|^2 dx} \leq \frac{a F_1}{\int_{-L}^0 |h|^2 dx}, \quad \sigma_I = \frac{a F_2}{\int_{-L}^0 |h|^2 dx}, \quad (27)$$

From (27)₁, we get $F_1 > 0$.

Next we show the second part of the lemma, namely $G \geq 0$. We multiply (8)₂ by f^* and integrate over $(-L, 0)$. Then we obtain

$$\eta \int_{-L}^0 h_{xx} f^* dx - (\sigma + k^2\eta) \int_{-L}^0 h f^* dx = a \int_{-L}^0 |f|^2 dx, \quad (28)$$

which is equivalent to

$$\eta \int_{-L}^0 h_{xx} f^* dx + (\sigma_R + k^2\eta + i\sigma_I)(F_1 - iF_2) = a \int_{-L}^0 |f|^2 dx. \quad (29)$$

The real part of this equation gives

$$\text{real}\{-\eta \int_{-L}^0 h_{xx} f^* dx\} = (\sigma_R + k^2\eta)F_1 + \sigma_I F_2 - a \int_{-L}^0 |f|^2 dx. \quad (30)$$

Using (27)₁ and (27)₂ in (30), we obtain

$$\begin{aligned} \text{real}\{-\eta \int_{-L}^0 h_{xx} f^* dx\} &\leq a \frac{F_1^2 + F_2^2}{\int_{-L}^0 |h|^2 dx} - a \int_{-L}^0 |f|^2 dx \\ &= \frac{a |\langle f, -h \rangle|^2}{\int_{-L}^0 |h|^2 dx} - a \int_{-L}^0 |f|^2 dx \\ &\leq 0, \end{aligned} \quad (31)$$

where we have used the Cauchy-Schwarz-Buniakowski inequality

$$|\langle f, -h \rangle|^2 \leq \int_{-L}^0 |h|^2 dx \int_{-L}^0 |f|^2 dx. \quad (32)$$

The definition of G (see (18)) and the inequality (31) implies $G \geq 0$. ■

The theorem-1 implies that maximum possible growth rate is less with diffusion than without diffusion. In other words, diffusion here suppresses instability, consistent with what is in general expected from intuition. However, as the following theorem shows it can completely stabilize the flow with proper amount of diffusion.

Theorem 2. *We have $\sigma_R \leq 0$ for large enough η .*

Proof. Consider $\sigma_R > 0$. Then, we have the estimate (20) for the maximum possible growth rate of unstable modes in the presence of diffusion. We can make the first term in the righthand side of (20) as small as we please by letting $\mu(0)$ near μ_r , $\mu(-L)$ near μ_l , and small a (i.e., small viscosity gradient in the middle layer), where as we can make the second term in the righthand side of (20) as large as we please in magnitude by letting the diffusion coefficient η large. Then the right hand side of (20) becomes negative for large enough η which is in contradiction with the hypothesis $\sigma_R > 0$. Therefore $\sigma_R \leq 0$ for large enough η . □

We know that the three-layer set-up discussed here with the viscosity gradient in the middle layer positive in the direction of displacement is intrinsically unstable without diffusion. The above theorem shows that such an unstable three-layer set-up in a Hele-Shaw cell can be completely stabilized with large enough diffusion in the middle layer.

Remark 1. *We recall here the Saffman-Taylor formula for the (real) growth rate, in the case of only one interface separating displaced fluid of viscosity μ_r from the displacing fluid of viscosity μ_l .*

$$\sigma = \frac{U\alpha(\mu_r - \mu_l) - \alpha^3 T}{\mu_r + \mu_l}. \quad (33)$$

The expression $\mathcal{P}/(-q)$ and $(-r)/s$, obtained from the relations (9) are quite similar with (33):

$$\begin{aligned} \frac{\mathcal{P}}{-q} &= \frac{U\alpha[\mu]_r - \alpha^3 T}{\mu_r}, \\ \frac{-r}{s} &= \frac{U\alpha[\mu]_l - \alpha^3 S}{\mu_l}. \end{aligned}$$

We can consider that the estimate (23) is a generalization of the Saffman-Taylor formula to the three-layer case with diffusion active in the middle layer. Moreover, we conclude that the maximum possible growth rate in the case $\eta \neq 0$ is less than the maximum possible growth rate in the case without diffusion. ■

4 Discussion and Conclusion

In this paper, we have considered Hele-Shaw flow is in the plane perpendicular to the direction of gravity and therefore gravity has not been incorporated in our formulation. From physical standpoint, gravity will bring in another complication because gravity will also induce gravity-driven instability at the interfaces (i.e. Rayleigh-Taylor instability) in addition to the Saffman-Taylor instability that we already have in the present formulation. Including gravity effect is a subject of research beyond the scope of this paper.

Since this paper may of interest to research community working on miscible flows and/or immiscible flows in porous media, it is important to stress the fact that the problem addressed in this paper involves immiscible phases in Hele-Shaw cell where the phases are treated distinct at macroscopic level with distinct boundaries called interfaces. Thus, field equations (1)-(3) do not involve surface tension. Surface tension rather appears in the boundary conditions (8) and (9) which arise from the balance of forces at the interfaces. The derivation of these equations is standard and has been addressed in [5], [6] by the authors. The nature of immiscible flows within Hele-Shaw model addressed in this paper is distinctly different from the same within saturation model commonly used in porous media. In saturation model, the Buckley-Leverett equation which is not present in our Hele-Shaw model allows mixing of immiscible phases at microscopic level. In the saturation model, the capillary pressure which is related to surface tension and Leverett function enters into the field equations directly (for example see Yortsos and Hickernell [36]).

Another aspect that needs to be stressed is that in the three-layer flow within the Hele-Shaw model, only the intermediate layer has polymer in water and polymer has a passive role in the sense that viscosity of the ploy-solution (i.e., the aqueous phase containing polymer) depends on its concentration in the aqueous phase. Diffusion of polymer is present in this aqueous phase only and is driven by the variation in gradient of the polymer concentration in this phase. There is no diffusion of the poly-solution or polymer at the interfaces unlike what would be the case for miscible flow.

In summary, we have derived exact results on the effect of diffusion of polymer in this three-layer immiscible flows using Hele-Shaw model. This has led to the following three main conclusions among many others.

1. Diffusion reduces the range of wave-numbers for which these flows are unstable and also their growth rates. This range can be empty for large enough diffusion.
2. An otherwise unstable three-layer Hele-Shaw flow can be completely stabilized by a large enough diffusion, i.e., by increasing enough the magnitude of the diffusion coefficient. The magnitude of this diffusion coefficient required to completely stabilize the flow will depend on the magnitude of interfacial viscosity jumps and the viscosity gradient of the basic viscous

profile of the middle layer.

3. We have provided a generalization of the Saffman-Taylor formula to the three-layer case with diffusion active in the middle layer.

These results are obviously of fundamental importance to many applications where stability of flows plays a decisive role. One instance of such application is that of enhanced oil recovery by polymer flooding as discussed briefly in the Introduction. Slobod & Lestz (1960) suggested the use of graded viscosity zone to reduce fingering in secondary oil recovery. This was subsequently studied by many using polymer in water as a means of producing graded viscosity fluid for flooding purposes in tertiary oil recovery using polymer in water as a means of producing graded viscosity fluid for flooding purposes in tertiary oil recovery (see Uzoigwe, Scanlon & Jewett (1974), Shah & Schechter (1977), Pearson (1977), Needham & Doe (1987), Littman (1988), Sorbie (1991), and Zhijun & Yongmei (2002)). Its use is continuing to this day. Our results show that diffusion of polymer during polymer-flooding process will further enhance oil recovery in reducing fingering. Our results is also forward looking in that it suggests that to further enhance oil recovery, it is worthwhile to look for ways to enhance diffusion process itself as it can completely eliminate fingering. Hopefully, these implications of our results in this paper will stimulate research in this direction.

5 Acknowledgments.

Part of this paper was completed while the second author (GP) was visiting the first author during the summer of 2005. The second author thanks the Department of Mathematics at Texas A&M University for providing this opportunity. The second author also acknowledges the support of CERES (2004) program. Finally, We would like to thank two anonymous referees for their helpful remarks.

References

- [1] Almgren, R. F.: 1995, Crystalline SaffmanTaylor fingers, *SIAM J. Appl. Math.* **55**, 1511-1535.
- [2] Chouke, R. L., van Meurs, P. and van der Poel, C.: 1959 The stability of a slow, immiscible, viscous liquid-liquid displacements in a permeable media, *Petrol. Trans. AIME* **216**, 188-194.
- [3] Darcy, H.: 1856, *Les Fontaines Publiques de la Ville de Dijon*. Victor Dalmond.
- [4] Daripa, P., Glimm, J., Lindquist, B. and McBryan, O.: 1988, Polymer Floods: A Case Study of Nonlinear Wave Analysis and Instability Control in Tertiary Oil Recovery, *SIAM J. Appl. Math.* **49** 353-373.

- [5] Daripa, P., and Pasa, G.: 2005, New bounds for stabilizing Hele-Shaw flows, *Appl. Math. Lett.* **18(11)**, 1293-1303.
- [6] Daripa, P., and Pasa, G.: 2006, A simple derivation of an upper bound in the presence of viscosity gradient in three-layer Hele-Shaw flows, *J. Stat. Mech.* 11 pages, P01014. doi:10.1088/1742-5468/2006/01/P01014
- [7] Duchon, J., and Roberts, R.: 1984, Evolution d'une interface par capillarité et diffusion de volume I. Existence locale en temps, *Ann. Inst. H. Poincaré, Anal. Non Linéaire* **1**, 361-378.
- [8] Escher, J., and Simonett, G.: 1996, On Hele-Shaw models with surface tension, *Math. Res. Lett.* **3**, 467-474.
- [9] Gorell, S.B., & Homsy, G.M.: 1983, A theory of the optimal policy of oil recovery by the secondary displacement process, *SIAM J. Appl. Math.* **43**, 79-98.
- [10] Hickernell, F.J. and Yortsos, Y.C.: 1986: Linear stability of miscible displacement processes in porous media in the absence of dispersion, *Stud. Appl. Math.* **74**, 93-115.
- [11] Hill, S.: 1952, Channelling in packed columns, *Chem. Eng. Sci.* **1** 247-253.
- [12] Homsy, G.M.: 1987, Viscous fingering in porous media, *Ann. Rev. Fluid Mech.* **19**, 271-311.
- [13] Howison, S.D.: 1986, Cusp development in Hele-Shaw flow with a free surface, *SIAM J. Appl. Math.* **46**, 2026.
- [14] Kadanoff, L. P.: 1990, Exact Solutions for the Saffman-Taylor Problem with Surface Tension, *Phys. Rev. Letts.* **65**, 2986-2988.
- [15] Kessler, D. A., Koplik, J. and Levine, H.: 1988, Pattern selection in fingered growth phenomena, *Adv. in Phys.* **37**, 255-329.
- [16] Littman, W.: 1988, *Polymer Flooding: Developments in Petroleum Science.* **24** Elsevier, Amsterdam.
- [17] Loggia, D., Rakotomalala, N., Salin, D. and Yortsos, Y.C.: 1999, The effect of mobility gradients on viscous instabilities in miscible flows in porous media, *Phys. Fluids.* **11(3)**, 740-742.
- [18] McLean, J.W. and Saffman, P.G.: 1981, The effect of surface tension on the shape of fingers in a Hele-Shaw cell, *J. Fluid Mech.*, **102**, 445-469.
- [19] Needham, R.B., and Doe, P, H.: 1987, Polymer flooding review, *J. Pet. Technol.* **12**, 1503-1507.
- [20] Nie, Q., and Tian, F.R.: 1998 Singularities in Hele-Shaw flows, *SIAM J. Appl. Math.* **58**, 3454.

- [21] Otto, F., and Weinan, E.: 1997, Thermodynamically driven incompressible fluid mixtures. *J. Chem. Phys.* **107**, 1017710184.
- [22] Oztekin, A., Cumbo, L.J. and Liakopoulos, A.: 1999, Temporal stability of boundary-free shear flows: The effects of diffusion, *Theor. comp. fl. dyn.* **13(2)**, 77-90.
- [23] Pearson, H. J.: 1977, *The stability of some variable viscosity flow with application in oil extraction*, Cambridge Univ. Report.
- [24] Saffman, P.G.: 1986, *Viscous Fingering in Hele-Shaw Cells*, *J. Fluid Mech.*, **173**, 73-94.
- [25] Saffman, P.G. and Taylor, G.I.: 1958, *The penetration of a fluid in a porous medium or Hele-Shaw cell containing a more viscous fluid*, *Proc. Roy. Soc. A* **245**, 312-329.
- [26] Shah, D. and Schechter, R.: 1977, *Improved Oil Recovery by Surfactants and Polymer Flooding*, Academic Press, New York.
- [27] Shariati, M. and Yortsos, Y.C.: 2001, Stability of miscible displacements across stratified porous media, *Phys. Fluids.* **13(8)**, 2245-2257
- [28] Slobod, R.L. and Lestz, J.S.: 1960, Use of a graded viscosity zone to reduce fingering in miscible phase displacements, *Producers Monthly* **24**, 12-19.
- [29] Sorbie, K.S.: 1991, *Polymer-Improved Oil Recovery*, CRC Press, Boca Raton, Florida.
- [30] Tanveer, S.: 2000, Surprises in viscous fingering, *J. Fluid Mech.* **409**, 273-308.
- [31] Tanveer, S. and Xe, X.: 2003, Analyticity and nonexistence of classical steady Hele-Shaw fingers, *Commun. Pure Appl. Math.* **56**, 353-402.
- [32] Tian, F.R.: 1996, A Cauchy integral approach to Hele-Shaw problems with a free boundary: the case of zero surface tension, *Arch. Ration. Mech. Anal.* **135**, 175-196.
- [33] Uzoigwe, A.C., Scanlon, F.C. and Jewett, R.L.: 1974, Improvement in polymer flooding: The programmed slug and the polymer-conserving agent. *J. Petrol. Tech.* **26**, 33-41.
- [34] Vasconceles, G.L. and Kadanoff, L.P.: 1991, Stationary solutions for the Saffman-Taylor problem with surface tension, *Phys. Rev. A.* **44**, 6490-6495
- [35] Xie, X. and Tanveer, S: 2003, Rigorous results in steady finger selection in viscous fingering. *Arch. Ration. Mech. Anal.* **166**, 219-286.
- [36] Y. C. YORTSOS AND F. J. HICKERNELL, *Linear stability of immiscible displacement in porous media*, *SIAM J. Appl. Math.*, 49(3), (1989), pp. 730-748.

- [37] Yortsos, Y.C. and Zeybek, M.: 1988, Dispersion driven instability in miscible displacement in porous-media, *Phys. Fluids*. **31(12)**, 3511-3518.
- [38] Zhijun, Z. and Yongmei, H.: 2002, Economic evaluation shows polymer flooding effectiveness, *Oil & Gas Journal*. **100(43)**, 56-59.