

### Section 7.3 Volumes by cylindrical shells

Lets find the volume  $V$  of a cylindrical shell with inner radius  $r_1$ , outer radius  $r_2$ , and height  $h$  (see Fig.1).

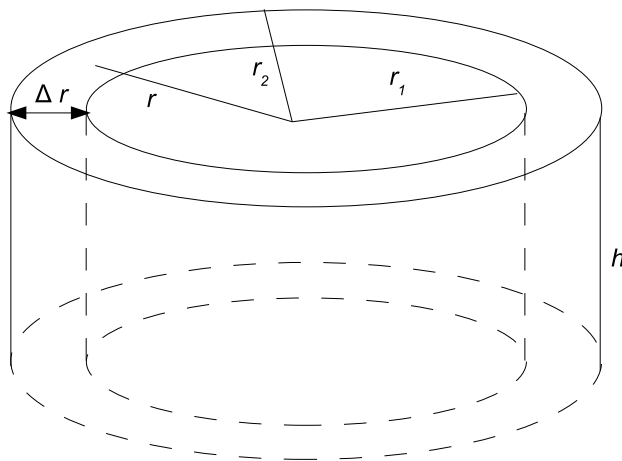

Fig.1

$V$  can be calculated by subtracting the volume  $V_1$  of the inner cylinder from the volume  $V_2$  of the outer cylinder:

$$V = V_2 - V_1 = \pi h(r_2^2 - r_1^2) = 2\pi h \frac{r_2 + r_1}{2} (r_2 - r_1)$$

Let  $\Delta r = r_2 - r_1$ ,  $r = (r_2 + r_1)/2$ , then the volume of a cylindrical shell is

$$V = 2\pi r h \Delta r$$

$$V = [\text{circumference}][\text{height}][\text{thickness}]$$

$$V = 2\pi[\text{average radius}][\text{height}][\text{thickness}]$$

Now let  $S$  be the solid obtained by rotating about the  $y$ -axis the region bounded by  $y = f(x) \geq 0$ ,  $y = 0$ ,  $x = a$ , and  $x = b$ , where  $b > a \geq 0$ .

Let  $P$  be a partition of  $[a, b]$  by points  $x_i$  such that  $a = x_0 < x_1 < \dots < x_n = b$  and let  $x_i^*$  be the midpoint of  $[x_{i-1}, x_i]$ , that is  $x_i^* = (x_{i-1} + x_i)/2$ . If the rectangle with base  $[x_{i-1}, x_i]$

and height  $f(x_i^*)$  is rotated about the  $y$ -axis, then the result is a cylindrical shell with average radius  $x_i^*$ , height  $f(x_i^*)$ , and thickness  $\Delta x_i = x_i - x_{i-1}$ , so its volume is  $V_i = 2\pi x_i^* f(x_i^*) \Delta x_i$ .

The approximation to the volume  $V$  of  $S$  is  $V \approx \sum_{i=1}^n 2\pi x_i^* f(x_i^*) \Delta x_i$ . This approximation appears to become better and better as  $\|P\| \rightarrow 0$ .

Thus, the volume of  $S$  is

$$V_Y = \lim_{\|P\| \rightarrow 0} \sum_{i=1}^n 2\pi x_i^* f(x_i^*) \Delta x_i = 2\pi \int_a^b x f(x) dx$$

**Example 1.** Find the volume of the solid obtained by rotating the region bounded by  $y = 2x - x^2$ ,  $y = 0$ ,  $x = 0$ ,  $x = 1$  about the  $y$ -axis.

The volume of the solid generated by rotating about the  $y$ -axis the region between the curves  $y = f(x)$  and  $y = g(x)$  from  $a$  to  $b$  [ $f(x) \geq g(x)$  and  $0 \leq a < b$ ] is

$$V_Y = 2\pi \int_a^b x[f(x) - g(x)] dx$$

**Example 2.** Find the volume of the solid obtained by rotating the region bounded by  $y = x^2$ ,  $y = 4$ ,  $x = 0$  about the  $y$ -axis,  $x > 0$ .

The method of cylindrical shells also allows us to compute volumes of revolution about the  $x$ -axis. If we interchange the roles of  $x$  and  $y$  in the formula for the volume, then the volume of the solid generated by rotating the region bounded by  $x = g(y)$ ,  $x = 0$ ,  $y = c$ , and  $y = d$  about the  $x$ -axis, is

$$V_X = 2\pi \int_c^d yg(y)dy$$

**Example 3.** Find the volume of the solid obtained by rotating the region bounded by  $y^2 - 6y + x = 0$ ,  $x = 0$  about the  $x$ -axis.

The volume of the solid generated by rotating the region bounded by  $x = g_1(y)$ ,  $x = g_2(y)$ ,  $y = c$ , and  $y = d$ , about the  $x$ -axis, assuming that  $g_2(y) \geq g_1(y)$  for all  $c \leq y \leq d$ , is

$$V_X = 2\pi \int_c^d y[g_2(y) - g_1(y)]dy$$

**Example 4.** Find the volume of the solid obtained by rotating the region bounded by  $y = 4x - x^2$ ,  $y = 8x - 2x^2$  about  $x = -2$ .